

68159-05

LEGEND

B	BATTERY
L	LOW
M	MEDIUM
R	HIGH
C	CLUTCH

KNOB, BLACK
PLASTIC WITH
WHITE IMPRINTING

SHAFT

MTG. STEM $\frac{7}{16}$ -28 UNEF

HEX NUT

SPROOF L'WASHER

MALE BLADE TERMINALS

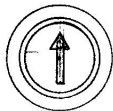
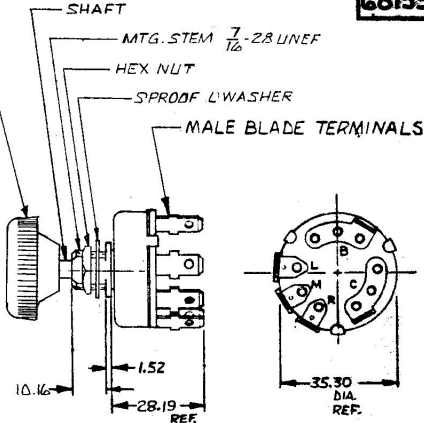
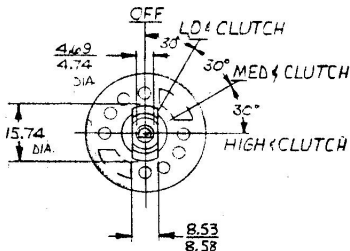

METRIC

FRONT VIEW
OF KNOB

NOTES:

1. IMPORTANT-NO BREAK IN CLUTCH CIRCUIT BETWEEN LOW, MEDIUM, & HIGH POSITION
2. SILVERED CONTACT SURFACES
3. MELAMINE LINER
4. ALL STEEL PARTS PLATED
5. ELECTRICAL RATING : 12/24VDC

Ⓐ

DO NOT SCALE

LET.	WAS	DATE	BY	LET.	WAS	DATE	BY	MATERIAL	DRAWN	CHECKED	APPROVED	SCALE	DATE DRAWN
								FRSH H	PS			1:1	9-28-83
								TOLERANCES DECIMAL ± METRIC ± .15					DATE BLUEPRINT
									Cole Hersee Co. A Division of The Emerson Electric Co.				
									AIR CONDITIONING SWITCH WITH CLUTCH CIRCUIT				

68159-05