

59024-218

MM	IN
0.96	0.032
1.82	0.072
11.93	0.470
19.05	0.750
30.48	1.200
33.52	1.320

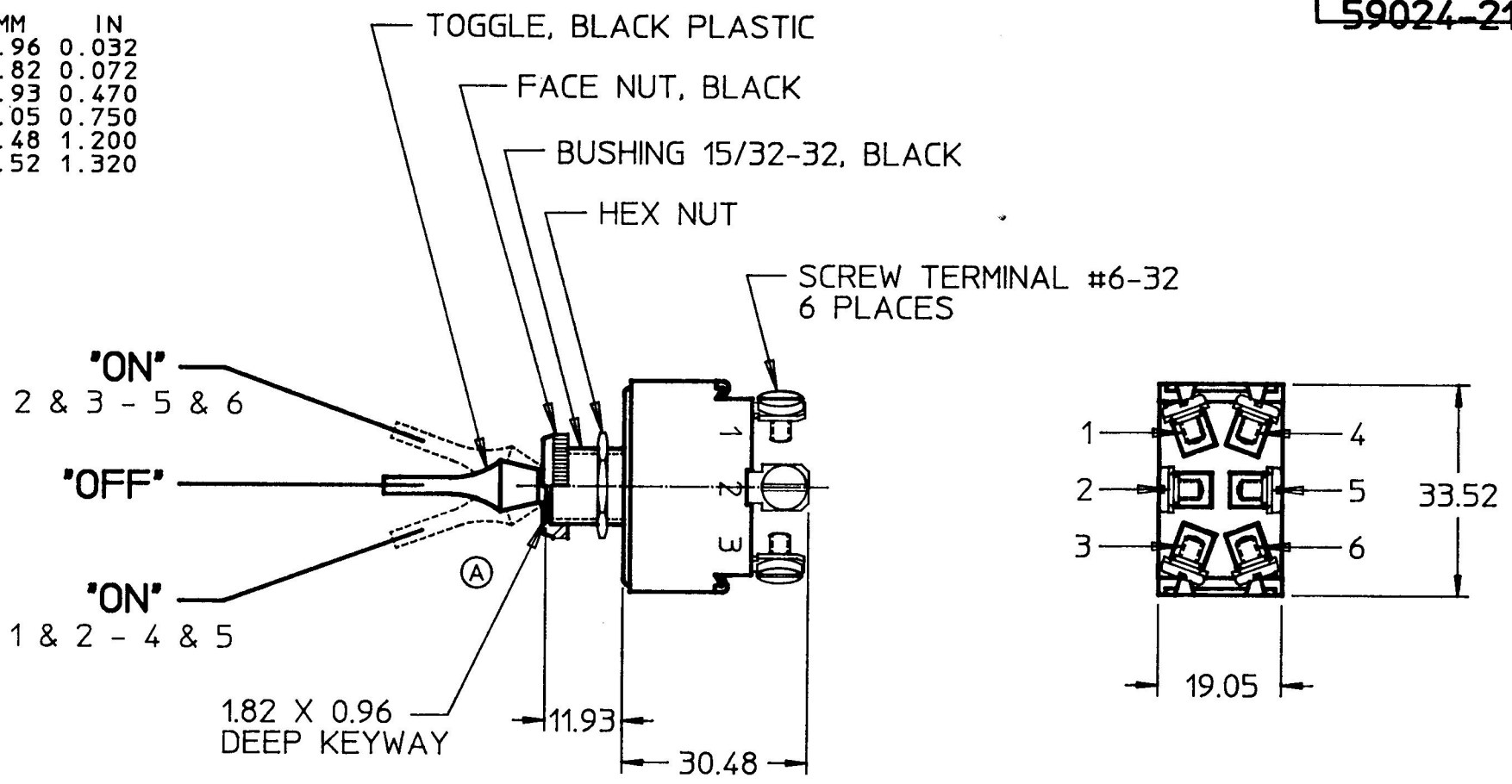

- NOTES:
1. ALL STEEL PARTS PLATED
  2. SILVER CONTACTS
  3. 25 AMPS @ 12VDC LAMP LOAD
  4. ALL DIMENSIONS REF. ONLY

METRIC

DO NOT SCALE  
CAD GENERATED

LET.	WAS	DATE	BY	LET.	WAS	DATE	BY	MATERIAL	DRAWN	CHK	APVD	SCALE	DATE DRAWN
									LIZ	AF		1:1	3/12/90
								FINISH	 <small>70 OLD COLONY AVENUE SOUTH BOSTON, MA U.S.A. 02127</small>				DATE BLUEPRINTED
				A	EDN 24519	8/22/90	RO	TOLERANCES					
					ISSUED	3/27/90	AF	DECIMAL ± ANGLE ±	SW, TOGGLE, DPDT				59024-218