

PART NUMBER

OLS43601ZX

REVISION

REV	DATE	DESCRIPTION
A	3/11/24	527585GCP - RELEASE PER EM3406 MRY

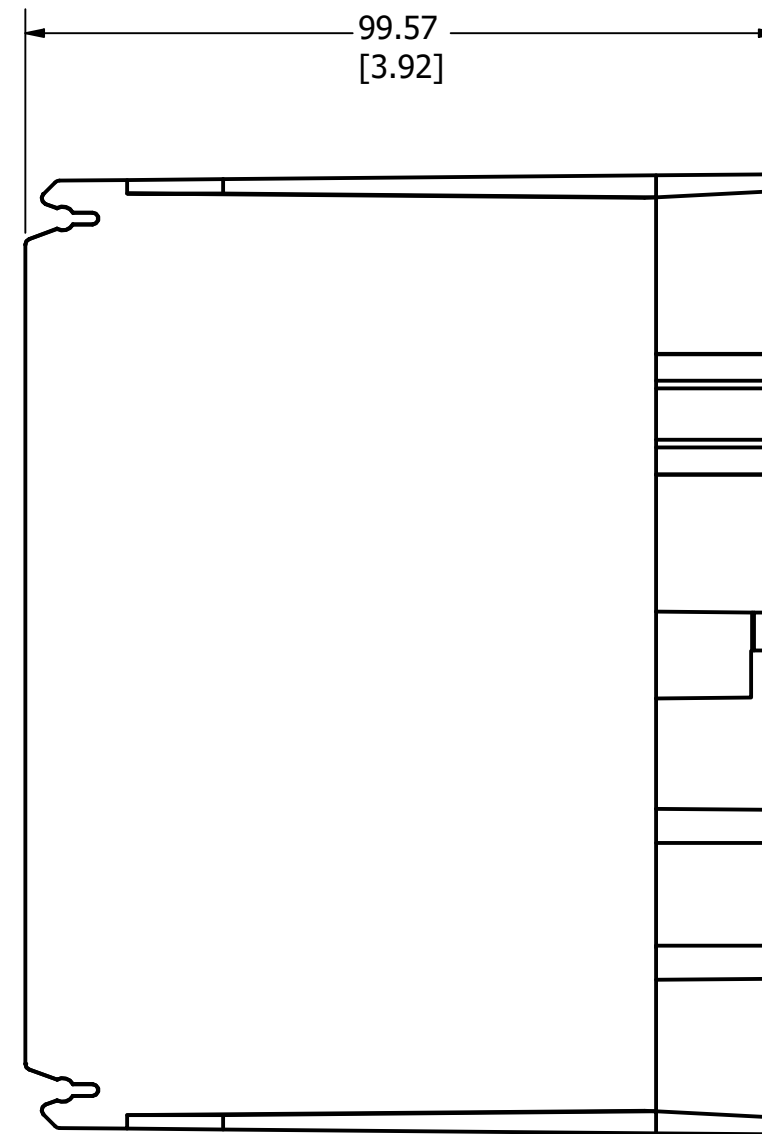
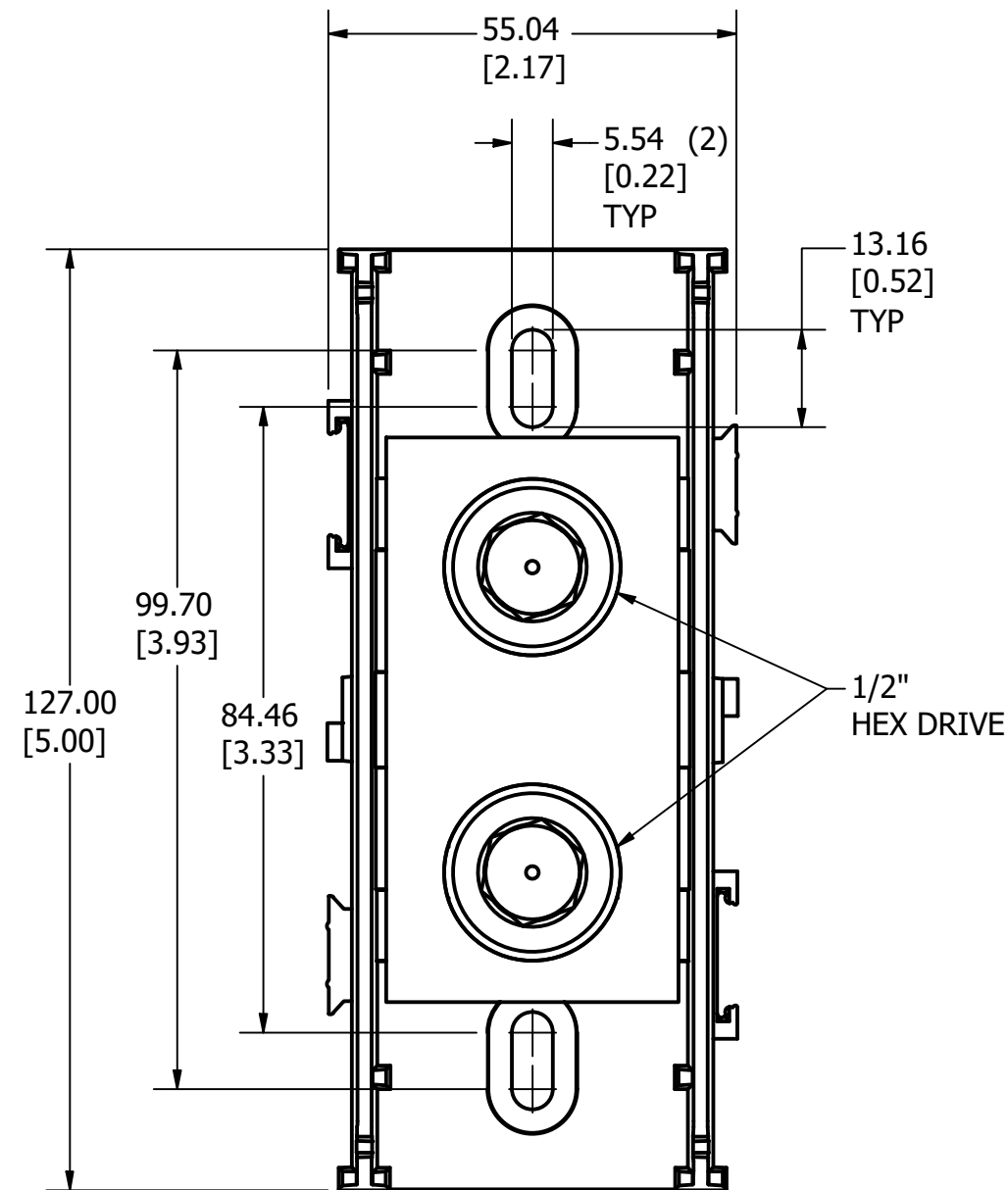

NOTES:

1. AGENCY INFORMATION: UL LISTED TO UL 1953
2. MATERIALS: INSULATOR BASE: HIGH IMPACT THERMOPLASTIC  
FLAMMABILITY RATING UL94V0  
TEMP RATING: -40°C TO 125°C (UL RTI)  
CONNECTOR: ALUMINUM, TIN PLATED  
TERMINAL SCREWS: ALUMINUM, TIN PLATED  
CONNECTOR MOUNTING SCREWS: STEEL, ZINC PLATED
3. TERMINATION: LINE: COPPER STRANDED & ALUMINUM, 600 KCMIL - #2 AWG  
LOAD: COPPER STRANDED & ALUMINUM, 600 KCMIL - #2 AWG
4. MAXIMUM AMP RATING PER POLE: 420A  
BASED ON NEC WIRE RATING CODE, 75°C WIRE  
PROVIDES SPACING FOR USE IN FEEDER CIRCUITS  
AT 251-600V PER UL508A
5. TORQUE: LINE: 600 KCMIL - #2: 42.4 N-m (375 lbf-in)  
LOAD: 600 KCMIL - #2: 42.4 N-m (375 lbf-in)
6. MOUNTING: USE #10 FASTENER. TORQUE NOT TO EXCEED  
3.4 N-m (30 lbf-in).

TOLERANCE (UNLESS OTHERWISE SPECIFIED):

- 1 PLACE ± 2.5mm [0.10]
- 2 PLACE ± 0.76mm [0.03]
- 3 PLACE ± 0.381mm [0.015]

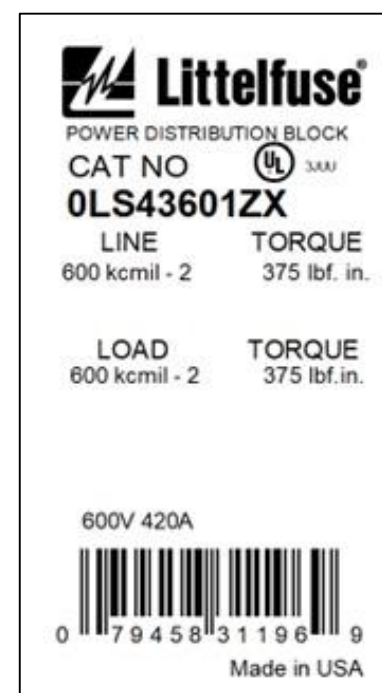
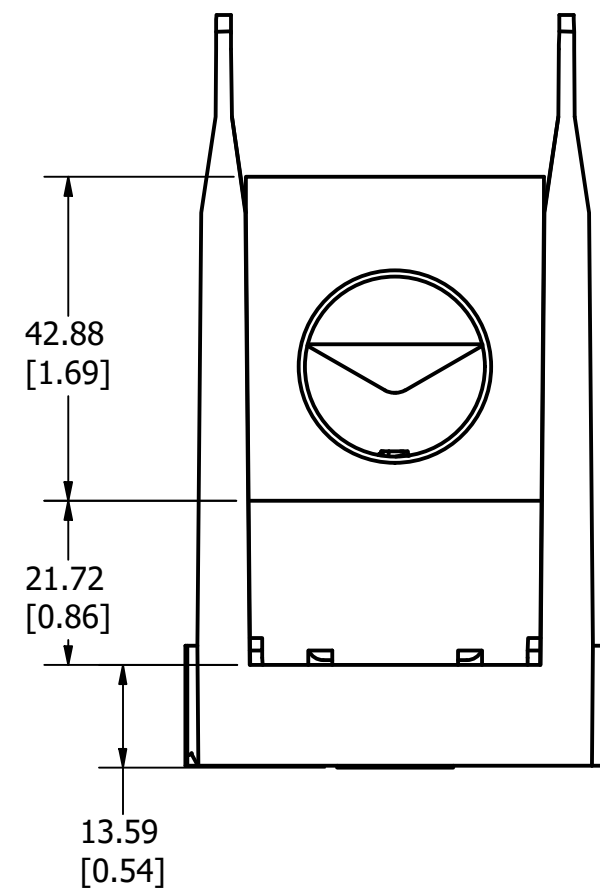

Suitable Wire, CU kcmil/AWG		Over-Current Protection Fuse Required Class / Max Amp Rating				SCCR RMS Sym. Amps 600V Max			
CLASS	LINE	LOAD	J	T	RK1	RK5	G	CC	
B-C	600-2	600-2	500	500	400	200	60	30	100,000
G, H, I	350-2	350-2	450	450	400	200	60	30	100,000
	600-2	600-2	None						10,000

PRODUCT LABELS

NO	COMPONENT NO	DESCRIPTION	QTY/M	U/M
<b>BILL OF MATERIAL</b>				
<S>		CRITICAL CHARACTERISTIC FOR PART SAFETY/COMPLIANCE		
●		DENOTES CRITICAL CHARACTERISTICS.		
CPK		DENOTES CPK DIMENSIONS, -MINIMUM CPK VALUE		
(ST)		DENOTES A CHARACTERISTIC THAT PROVIDES AN INDICATION OF PROCESS PERFORMANCE. PROCEDURE FOR MEASUREMENT AND TRACKING TO BE DEFINED IN LITTELFUSE INSPECTION INSTRUCTIONS.		
CP		DENOTES CP DIMENSIONS, -MINIMUM CP VALUE MUST BE WITHIN THE DIMENSIONAL LIMITATIONS SHOWN ON DRAWING AND INITIALLY LOCATED TO ALLOW FOR MAXIMUM TOOL LIFE.		<b>C</b>
MATL SPEC		FINISH		
DRW myork	DATE 3/7/2023	SCALE NTS	FINISH GOOD WT GRAMS/PIECE	
UNLESS OTHERWISE SPECIFIED, DIMENSIONS ARE IN MILLIMETERS, DIMENSIONS IN BRACKETS [ ] ARE INCHES DIMENSIONING AND DO NOT INCLUDE PLATING. TOLERANCING TO BE INTERPRETED IN ACCORDANCE WITH ANSI Y14.5M-1994				
3RD ANGLE PROJECTION				
<b>TITLE</b> SPLICER BLOCK 600V, 420A, 1 POLE OUTLINE				
<b>Littelfuse</b> CHICAGO, ILLINOIS 60631		REVISION A	DRWG NO. OL-LS43601	SHEET 1 OF 1