

## Techniques for Protecting Smart Sweeping Robots



### Abstract

In recent years the development of information technology, artificial intelligence, sensor techniques and mobile-robot technology has led to intelligent systems being applied to smaller household appliances. One of the most representative products of this trend is the smart sweeping robot. Since the launch of the very first commercial sweeping robot in the USA in 2002, sweeping robots have become increasingly popular around the world. Consumers everywhere, including in China, can now relax while a smart sweeping robot cleans and dusts their floors.

Because a smart sweeping robot cleans the floor independently, it is likely that it will at times be operating when no one is there to supervise it. In the event of any mechanical or electrical failure therefore, the components must be protected by a timely shut-down, to avoid any damage. Then, after troubleshooting, the unit can be restored to normal operation. It follows that for the manufacturers of smart sweeping robots, the intelligence of the product is of primary importance, while having a reliable, high-quality product is equally important for

the consumer. This article discusses several solutions for improving the protection of smart sweeping robots.

### Resettable Circuit Protection with PPTC Devices

Littelfuse is the preferred brand for leading manufacturing around the world. PolySwitch, a business unit of the company, is a provider of circuit protection devices, and the commercial pioneer of polymer positive temperature coefficient (PPTC) resistance technology. Its overcurrent and overvoltage protection devices are widely used in consumer electronics, IT equipment, communications technology, general industry, the automotive industry, and other fields. Littelfuse products include PolySwitch resettable devices for overcurrent protection, gas discharge tubes (GDTs) for overvoltage protection, and PESD/SESD devices for electrostatic discharge (ESD) protection, as well as a number of integrated protective components, including 2Pro, PolyZen and MHP devices.

Littelfuse offers a wide array of PolySwitch devices, including radial-leaded, surface-mount and LVR devices with voltage ratings from 16V<sub>DC</sub> up to 240V<sub>AC</sub>. All PolySwitch devices feature low resistance, rapid response time, small size and reset functions, all of which help circuit designers develop safe and reliable products.

PolySwitch devices are specifically used to help prevent damage resulting from overload, overheating, stalled motors, neutral line failures and other conditions that may damage electric motors, controllers and transformers in both commercial and home-use electric appliances. PolySwitch devices are also available as strap devices for battery protection.

Like traditional one-use fuses, these devices limit the flow of dangerously high current during fault conditions. The PolySwitch device, however, resets after the fault is cleared and power to the circuit is cycled, thereby helping to reduce warranty, service and repair costs. Compared to many dual-metal breaker products, PolySwitch components offer greater flexibility of design, a longer service life and lower electromagnetic interference (EMI).

## Techniques for Protecting Smart Sweeping Robots

### Smart Sweeping Robot: Principle of Operation

Smart sweeping robots avoid obstacles in their path by using an ultrasonic ranging sensor which emits ultrasonic pulses in the direction of travel and receives corresponding return acoustic pulses. Ultrasonic emission and reception are controlled by devices that have either a microcontroller, or a DSP (digital signal processor), as their core. The robot's control system uses this data to determine an optimized path; it then engages the two step motors and activates the drive wheels, initiating the travel function. As the robot follows this optimized travel path, the onboard cleaning units are activated to perform dust removal and floor cleaning.

In general, a smart sweeping robot consists of a travel mechanism, a sensor system, a control system, a sweeping system and a power supply unit. The travel mechanism occupies a large part of the body of a smart sweeping robot, and its size determines the amount of operating space the robot requires. Wheeled systems are generally employed for home-use sweeping robots. Ultrasonic sensors, contact and proximity sensors, infrared sensors, etc., are utilized to allow the sensor system to gather information about complex environments. The control system analyzes this data from the various sensors in order to control the operation of the robot, allowing it to navigate correctly and carry out its cleaning functions.

The sweeping system generally consists of master floor brushes, side brushes and vacuum cleaners. Master floor brushes and side brushes are used to sweep up dirt and debris using mechanical force, while vacuum cleaners are used to remove smaller dust particles from the floor.

The power supply comprises the components that provide power to the various parts of the smart sweeping robot. Since the sweeping robot operates autonomously, the power supply is a rechargeable battery. This not only allows for unmanned control but also improves the equipment's functionality and flexibility. When fully charged, the robot can operate nonstop for several hours.

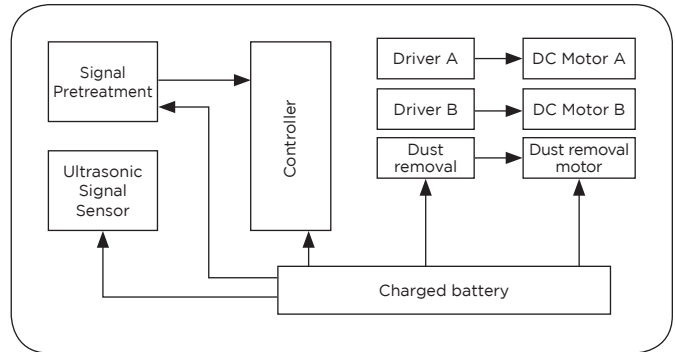

Figure 1: The functions of a smart sweeping robot

### Specifying PolySwitch Devices

The following is a general operational flowchart for the selection of suitable PolySwitch devices.

The first step is to determine the upper limit of the resistance of the PolySwitch devices,  $R_{1max}$ . Figure 2 describes how to calculate  $R_{1max}$ .

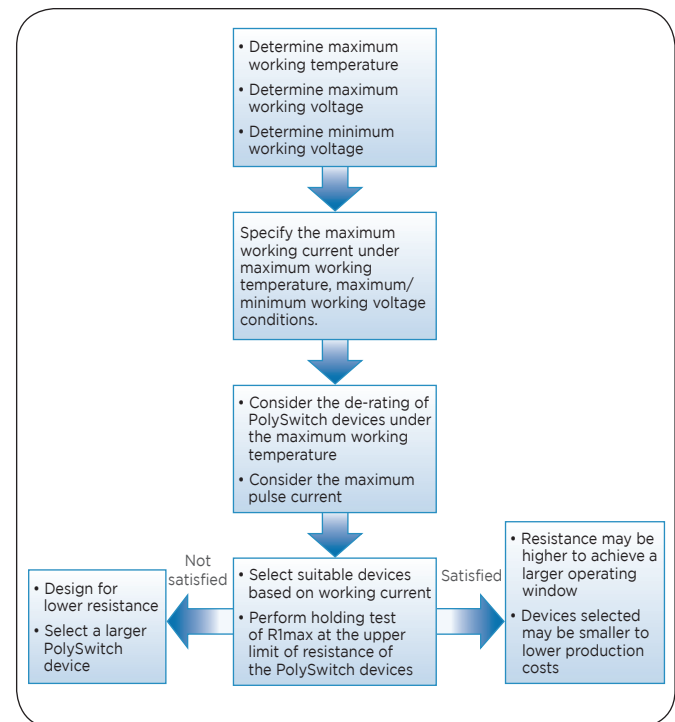

Figure 2: Calculating  $R_{1max}$

## Techniques for Protecting Smart Sweeping Robots

It is also necessary to determine  $R_{min}$ , the lower limit of the resistance of the selected PolySwitch devices as shown in Figure 3.

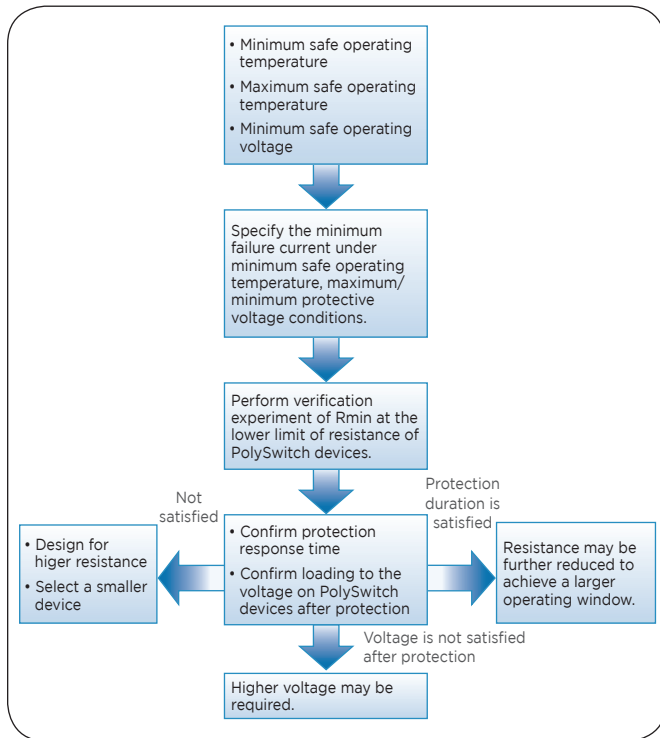

Figure 3: Calculating  $R_{min}$

Finally, it is necessary to determine the physical dimensions of the selected PolySwitch devices to ensure that they meet the space requirements of the design.

### Preventing a Stalled Motor

While floor cleaning is in progress – due to the unpredictability of the material that may be removed from the floor surface, such as hair or wire – the motorized parts of a smart sweeping robot may become entangled as they travel, causing the motor to stall. In other words, stalling occurs when foreign objects prevent the motor bearing from turning. When this happens, voltage is still being supplied to the motor, but current can no longer flow. When this type of stall occurs, the temperature of the motor will rise rapidly. When the temperature exceeds

the capacity of the motor coil, the coil can burn out, causing the motor to fail. This not only inconveniences the consumer but can also add to the cost of warranty repairs incurred by the manufacturer. The most practical solution to this potential problem is to incorporate reliable protection to help prevent a stalled motor. With this solution, once the cause of the stall has been removed, the customer can expect that the robot will return to normal operation with no further maintenance requirements. PolySwitch devices help enable this functionality since their resistance can be restored to a low value after a motor malfunctions.

The requirements for the protection of motors are set out in Clause 5.3.2 of the General Requirements for the Safety of IEC/EN60950 Information Technology Equipment. In the installation specifications for UL1017 vacuum cleaners, air blowers and household floor cleaning products, in Clause 4.8.3.1, there is also a detailed set of requirements for preventing the overloading of motors. In addition, the general requirements for the safety of EN 60335-1 household appliances and similar electrical appliances contain a similar set of requirements.

A smart sweeping robot features a dual-drive system with independent left and right motorized wheels. Both wheels are equipped with motors and photoelectric sensors. They receive control signals from the control system and provide feedback on movement to the control system. The sweeping system of a smart sweeping robot includes the master floor-brush sweeping devices, driven by the master floor-brush motors, and side-brush sweeping devices driven by the side-brush motor. It also includes a dust-removal device, generally a vacuum cleaner that is driven by a separate motor. So in a smart sweeping robot there are two driving-wheel motors, one master floor-brush motor, one side-brush motor and one dust-removal motor – five electric motors in all.

The following is an analysis of problems that can be encountered when attempting to prevent stalling of the motor, using the wheel-driving motors as an example.

## Techniques for Protecting Smart Sweeping Robots

The requirements, when the drive system is designed, are as follows. The maximum working current of a driving-wheel motor is 0.3A. The minimum temperature of the environment around the PCBs of the sweeping robot is 10°C, and the maximum operating temperature is 50°C. The maximum voltage of the charged batteries is 22.5V. Each motor requires protective components, attached to the motor surface, capable of providing protection by shutting off the current within 10 seconds of fault detection.

First, let us consider PolySwitch miniSMDC050F devices. Product specifications for this product line state that the allowed maximum sustained voltage is 24V. The current that can be sustained at an operating temperature of 50°C is 0.43A, which fulfils the requirements for sustaining a 0.3A current at the maximum operating temperature of 50°C.

Next, it is necessary to test the response time for motors that stall when operating at an ambient temperature of below 10°C, to determine if they meet the requirements for shut-down within 10 seconds.

The following test case utilizes miniSMDC050F devices with a resistance specified by Rmin. Figure 4 shows the real-time response for protection of a stalled wheel motor. As can be seen from the graph, the protection response time is 3.0 seconds, far less than the 10 seconds required

by the standard, which fulfills the requirements for the protection of the driving-wheel motors.

In the same way, the appropriate PolySwitch devices can be selected to be attached to the respective motor surfaces to protect the master floor-brush motors and side-brush motors from damage from overcurrent conditions.

For the dust-removal motors, due to their higher working current, rated for a maximum 2.9A, plus the requirement that the components be able to exceed 22.5V, a surface-mount PolySwitch device may not be suitable. However a radial-leaded component, such as the RUEF400 device, is appropriate. This device is able to hold a current of 3.08A at an ambient operating temperature of below 50°C and has a maximum voltage of 30V.

The response time for protection, following a dust-removal motor stall, for the RUEF400 device is determined by Rmin at an operating temperature of 10°C. Figure 5 shows the real-time response for protection in the event of a stalled dust-removal motor. As seen in the graph, its protection response time is 6.0 seconds, lower than the 10-second response time required by the standard and fulfils the requirements for protection of a stalled dust-removal motor.

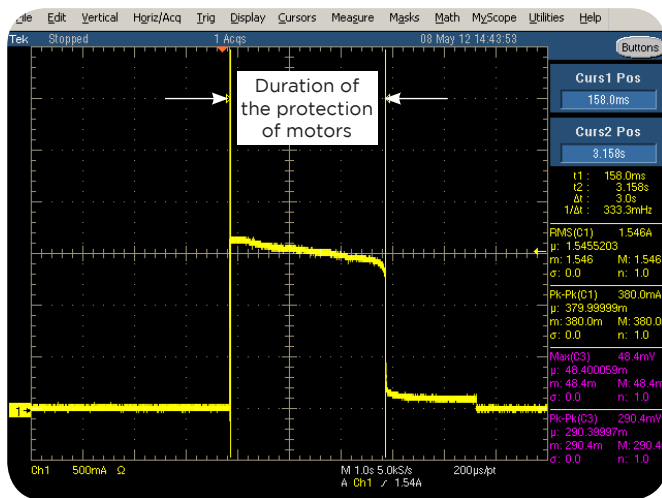

Figure 4: Real-time response for protection of a stalled wheel motor using a PolySwitch device.

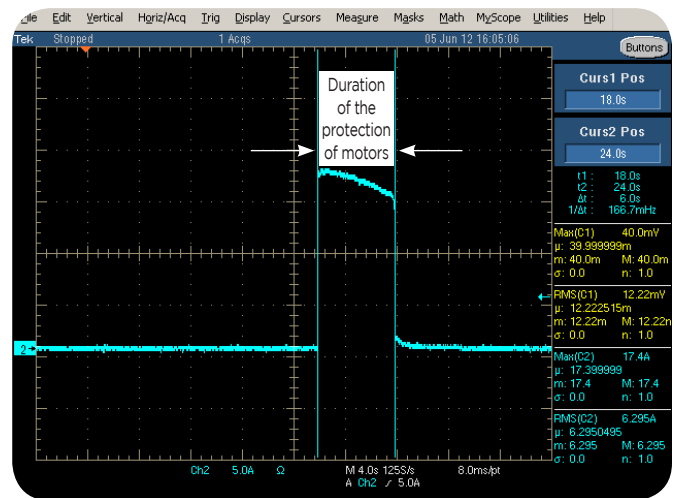

Figure 5: Response time for protection of a stalled dust-removal motor using a PolySwitch device.

## Techniques for Protecting Smart Sweeping Robots

### Protecting Power-charging Ports and Rechargeable Batteries

Smart sweeping robots can perform cleaning tasks automatically, even when the home is unoccupied. When their power level is low, smart sweeping robots can also automatically return to the charging station for recharging. This recharging function is very convenient; but since the charging ports are exposed, it is necessary to provide protection against external short circuits and other failures.

Resettable PolySwitch devices are a popular solution for port protection in a wide range of applications. Figure 6 illustrates the functions of the charging-port circuit of a smart sweeping robot. Since smart sweeping robots are powered by a rechargeable battery and will not exceed 30V, the radial-leaded PolySwitch devices with rated values of 16V<sub>DC</sub>, 24V<sub>DC</sub>, 30V<sub>DC</sub> are well suited to this application. Additionally, the low-rated PolySwitch devices can be placed on the AC mains charger for input side (secondary side) protection. Based on the working current levels and ambient operating temperatures for smart sweeping robots, the RUEF400 device will meet the relevant requirements.

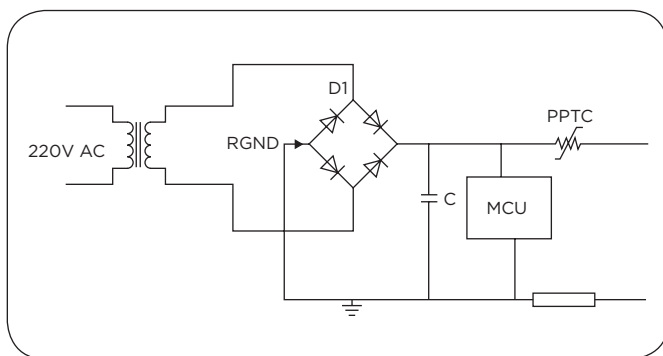

Figure 6: Circuit diagram of a charging port on a smart sweeping robot.

Rechargeable batteries provide power for smart sweeping robots. Various types of batteries can be used, including nickel-cadmium, lithium, and polymer batteries, all of which require protection against electrical surges or failures. PolySwitch devices are widely used as secondary protection devices in these applications, providing both overcurrent and over-charging protection. The overcurrent function helps protect against abnormally high-charging or discharging currents to prevent damage and ensure battery safety. The over-charging protection function monitors the battery core temperature to help prevent over-charging, enabling disconnection from the charger if such a condition occurs.

### Conclusion

Smart sweeping robots have become more popular around the world, and ensuring their safety and reliability is an important design consideration. PolySwitch PPTC devices are well-suited to helping protect the equipment's motors, batteries and charging ports from damage caused by stalled motors, overcharging and other failures that can be encountered during normal operation. Littelfuse offers appliance manufacturers a broad line of versatile, high-quality protection components and works closely with customers to develop solutions for specific applications.

#### Notice:

Information furnished is believed to be accurate and reliable. However, users should independently evaluate the suitability of and test each product selected for their own applications. Littelfuse products are not designed for, and shall not be used for, any purpose (including, without limitation, military, aerospace, medical, life-saving, life-sustaining or nuclear facility applications, devices intended for surgical implant into the body, or any other application in which the failure or lack of desired operation of the product may result in personal injury, death, or property damage) other than those expressly set forth in applicable Littelfuse product documentation. Warranties granted by Littelfuse shall be deemed void for products used for any purpose not expressly set forth in applicable Littelfuse documentation. Littelfuse shall not be liable for any claims or damages arising out of products used in applications not expressly intended by Littelfuse as set forth in applicable Littelfuse documentation. The sale and use of Littelfuse products is subject to Littelfuse Terms and Conditions of Sale, unless otherwise agreed by Littelfuse.