

How to Design Crowbar Protection in High-power Applications

Objectives

This document outlines how to approach the design of a protective device called Crowbar. Figure 1 is an example of using a three-phase, thyristor-based crowbar as a means of superordinate protection in industrial installations.

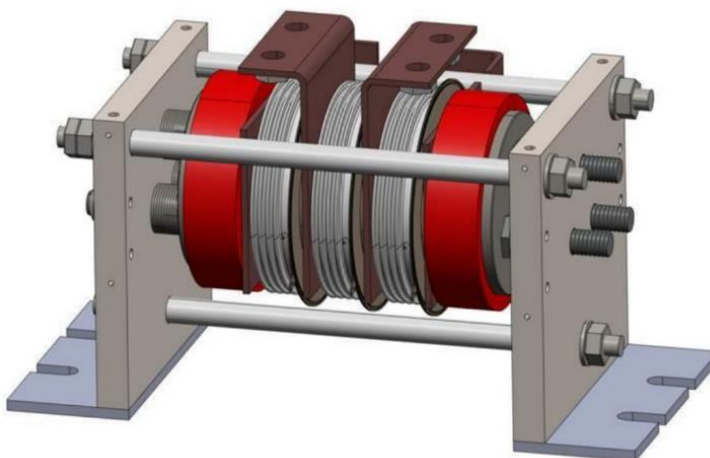

Figure 1: Thyristor-based, 3-phase Crowbar in Δ -connection

Applications

- Medium-voltage drives
- High-power industrial installations
- Utility-scale wind- and solar power
- Tram- and subway stations

Target Audience

This document is intended for all engineers designing protective entities in high-power applications.

Contact Information

For more information on the topic of crowbars or power semiconductor disc-devices, contact the Littelfuse Power Semiconductor team of product and applications experts:

- PowerSemiSupport@Littelfuse.com

Table of Contents

1. General Operating Principle of a Crowbar	4
2. Designing the Crowbar	6
2.1. Resettable Crowbar	7
2.2. Non-resettable Crowbar	8
3. Rupture-enhanced Disc Devices	10
4. Electro-mechanical Considerations.....	11
5. Conclusion.....	12

List of Figures

Figure 1: Thyristor-based, 3-phase Crowbar in Δ -connection.....	1
Figure 2: Low-power, DC-crowbar	4
Figure 3: Crowbar Schematics in 3-phased Applications (Y-connected setup to the left and Δ -connected setup to the right).....	5
Figure 4: Cross-section of High-power Thyristor Disc-device.....	5
Figure 5: Short Circuit Current Simulation for a High-power Medium-voltage Transformer	6
Figure 6: Estimated junction temperature development, N7905FE220.....	7
Figure 7: Thyristor-based, 3-phase Crowbar in Δ -connection.....	8
Figure 8: Estimated Junction Temperature Development, N73533ZD	9
Figure 9: Comparison between the N7905FE220 (resettable) and N3533ZD200 (single use) Components	9
Figure 10: Components of the Rupture-enhanced Package Technology.....	10
Figure 11: Disc opened for analysis.....	10
Figure 12: Disassembled disc-device	10
Figure 13: Closest proximity for Parallel Conductors in the Crowbar Stack.....	11

Introduction

According to the dictionary, the word *crowbar* originates from an Americanism, *crow* and *bar*, so called because one end was beak-shaped. By definition, a crowbar is a steel bar, usually flattened and slightly bent at one or both ends, used as a lever to pry things open.

In power electronics, the word became a metaphor for an electric approach that looks like using brute force to handle failure-events by initiating a controlled overcurrent situation and at the same time, safely trigger superordinate fuses or protective switch gear.

Protecting electronic devices is an omnipresent task for electrical engineers but is not limited to single applications. Far larger installations like industrial areas, solar inverters for utilities, multi access-point EV-charging stations or train- and subway-train stations need to be protected from hazardous conditions as well.

Classical fuses may not be able to protect power semiconductor switches when dealing with high power levels. Crowbars can be used to clear short circuits by diverting currents through themselves, thus giving enough time to fuses or protecting switch gear to disconnect the short circuit's cause. In addition, crowbars can be triggered in case of overvoltage and act as a supporting safety measure as well.

This white paper focuses on several aspects in designing reliable crowbars to be used as protecting instances in medium-voltage driven applications.

1. General Operating Principle of a Crowbar

In case a failure event like voltage rise or overcurrent is observed, and a critical limit is exceeded, a signal is generated that triggers a safety-switch to on-state. To get the speed necessary for the protection purpose, semiconductor switches are preferred as mechanical switches simply remain too slow. Though literally any semiconductor switch could be considered, the unique properties of thyristors make them the predestined choice for this application. Triggering a short circuit and the expectation to handle the resulting current for tens of milliseconds rules out IGBTs and MOSFETs that offer a short-circuit withstand time of no more than 10 μ s.

Once triggered, the voltage at the system's output is reduced to the thyristor's on-state voltage and a high current is generated that safely triggers a superordinate fuse. For a low-voltage DC-application, a simplified schematic of such a design is given in Figure 2.

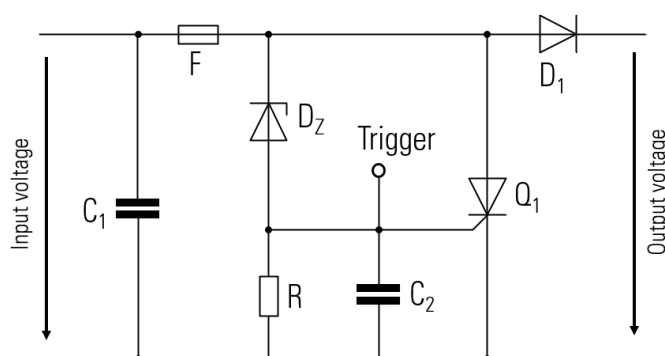

Figure 2: Low-power, DC-crowbar

The setup allows handling of two different failure scenarios:

- Once an overvoltage occurs at the DC-link capacitor C_1 , thyristor Q_1 is triggered via the breakover diode D_z . The capacitor is short-circuited by a low-inductive path and the resulting current triggers the fuse F .
- An overcurrent or even a short-circuit is detected by an additional sensor or system component and a trigger-signal is generated from an external source to turn the thyristor on. Consequently, the short-circuit is diverted into the thyristor and again, the current driven by the DC-link capacitor triggers the fuse.

Depending on the combination of fuse and thyristor, the semiconductor remains intact while the fuse can be replaced after the failure's root cause is eliminated. In larger installations, fuse and semiconductor will be replaced, independent of their status.

In case a short circuit current occurs in a power converter which deals with power levels in the MW-regime, classical fuses usually fail to protect power semiconductor switches like IGBTs or MOSFETs. This is because their I^2t -value is much higher than the one specified for the power semiconductor. Mechanically protecting switch gear or pyro-fuses are also too slow to clear the short circuit current before the converter's power semiconductor switches are destroyed – typically within a time less than 20µs.

To reliably protect the power semiconductor switches, the short circuit current must be moved from its original location to a new and non-critical one, using a thyristors-based crowbar. Here, the current will no longer circulate through the sensitive power semiconductor switches and the crowbar withstands the stress long enough to give time for mechanical protection switchgear to clear the short circuit event [1] [2].

A similar approach as in the DC-application can be followed in AC-based applications, however handling the energies involved becomes a challenge for the designer when choosing a proper thyristor. The two schematics represented in Figure 3 can be considered for a crowbar design in a 3-phased AC-scenario.

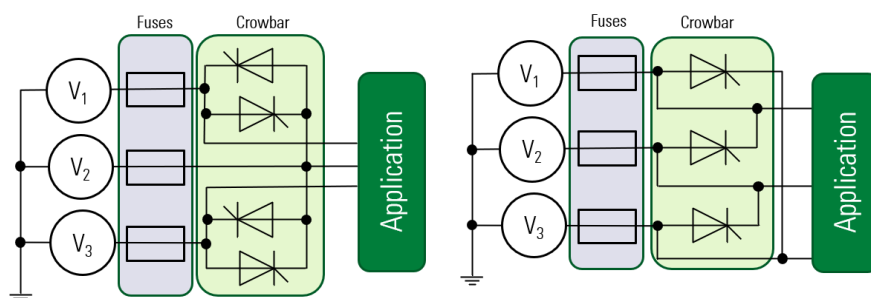

Figure 3: Crowbar Schematics in 3-phased Applications (Y-connected setup to the left and Δ-connected setup to the right)

The special requirements of the crowbar include that the thyristors, after being triggered, maintain the short-circuit condition until the fuse or a circuit breaker has reacted. This requires safe operation of the crowbar for at least 50 milliseconds.

To fulfill the safety function, it is tolerable that the thyristors lose their switching capability if the line-to-line connection reliably remains in low-impedance state.

In addition, the thyristors need to remain mechanically undamaged during the process. Destruction of the semiconductor's housing, so-called case rupturing, may not take place as it may influence the safety function. In addition, housing fragments pose a safety concern when driven like shrapnel through the setup by an expanding pressure wave. These requirements, along with the enormous currents to be handled, make so-called disc-devices the technology of choice.

In contrast to devices based on solder-bond technology, the electrical contact within disc-devices is created by pressing terminal plates to both sides of the monolithically integrated, single-wafer semiconductor. A cross-section of such a device can be seen in Figure 4.

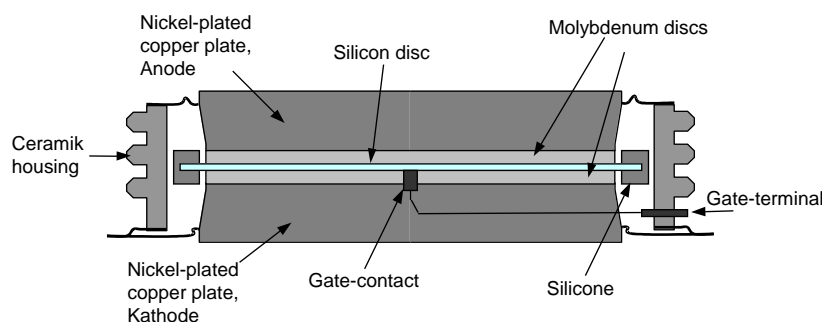

Figure 4: Cross-section of High-power Thyristor Disc-device

2. Designing the Crowbar

High-power crowbars are designed according to the needs of the individual application. In contrast to fuses, crowbars are not available as off-the-shelf-components and careful evaluation of each new use-case is mandatory to choose a properly dimensioned system. Also, crowbars should not be misunderstood as being fuses or even replacing fuses.

By design, crowbars are black boxes that can safely tolerate a high current with the target to trigger fuses. Therefore, a cross-check needs to be done to verify that the fuse or further superordinate switch gear is properly dimensioned as well.

As the most important parameter, the short circuit current to be expected has to be estimated, either taken from the datasheet of the power-source in place or potentially by simulation. Trivially, it should be mentioned that the blocking voltage of the thyristors must be compatible to the application's system voltage.

Figure 5 gives an example of the current the crowbar would have to withstand in combination with a MW-scale medium-voltage transformer,

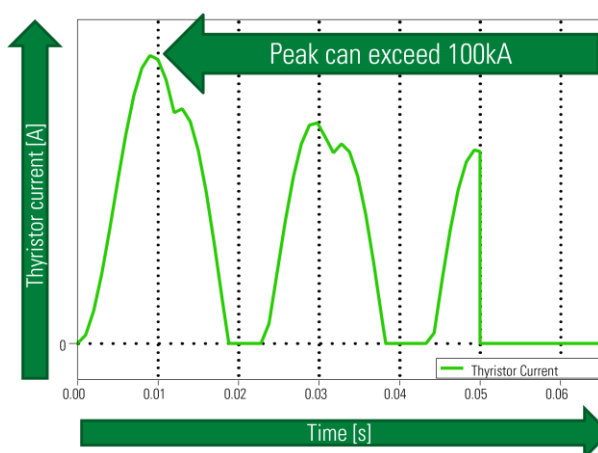

Figure 5: Short Circuit Current Simulation for a High-power Medium-voltage Transformer

It is a recurring expectation that classical fuses or mechanical switchgear can clear the short-circuit within 50 milliseconds, which is why the current in the simulation then reaches zero.

With the simulated current profile, a second simulation can be fed to estimate the temperature development in a chosen thyristor device.

2.1. Resettable Crowbar

It is important to notice that the confidence-level for such a simulation is limited. The thyristor first tried is a N7905FE220. As one of the largest of its kind, it features a rated current $I_{T(AV)M}$ of almost 8000 A if proper cooling is installed. The device's forward characteristic is given in the datasheet, but measured or guaranteed values are only given for the normal mode of operation. There is no guaranteed value for the forward voltage at current-levels exceeding the rated current by a factor 10 like in this example. Still, by experience, it remains reasonable to base the simulation on mathematical description for the forward voltage that can be extracted from the datasheet:

$$V_T = A + B \cdot \ln(I_T) + C \cdot I_T + D \cdot \sqrt{I_T}$$

The coefficients A-D needed are also found in the component's datasheet:

25°C Coefficients		125°C Coefficients	
A	1.045117	A	0.619127
B	-0.033344	B	2.437586×10^{-3}
C	1.7×10^{-5}	C	1.77434×10^{-5}
D	4.116×10^{-3}	D	4.566545×10^{-3}

Due to the rapid heating of the thyristors, calculations should be based on the 125°C coefficients.

Figure 6 depicts the estimation of the temperature development in a large-area phase-control thyristor type N7905FE220 [3] according to a PLECS-simulation.

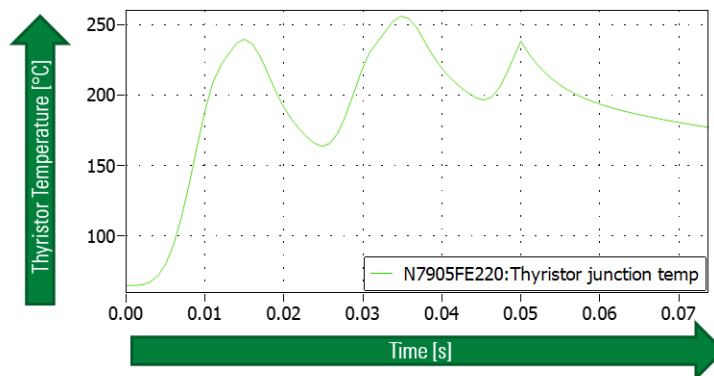

Figure 6: Estimated junction temperature development, N7905FE220

From the result gained from the simulation and presented in Figure 6, it becomes obvious that the maximum junction temperature of the die is exceeded. The maximum allowed is given with 125°C but again, permanent operation needs to be differentiated from this pulse-power mode.

For a single event, the junction temperature can reach 350°C without destroying the thyristor, if the event only remains in the milli-second regime.

From the result it can also be concluded that the device could cope with this pulse-power-style mode of operation quite well and presents an option even for multiple uses. This would qualify the approach as a resettable design.

2.2. Non-resettable Crowbar

Given that a crowbar can protect installations worth millions of Euro – or US\$ – the function is considered critical. Even if the thyristors seem to survive the event without damage, it is often demanded that the complete crowbar is replaced after activation, the same way a fuse is replaced. This opens the path to a design that tolerates that the semiconductors lose their switching capabilities during the failure event as long as the low-impedance short-circuit path remains intact.

Presspack devices are mounted in a composite – the so-called stack – by means of high pressure forces. Electrical damage to the silicon, for example due to high local current densities or too intensive heat generation, causes the silicon wafer to become a conductor at these points. This destroys the thyristor as a component, but the function "safely create a short circuit" is retained.

The disc cell, unlike power semiconductor modules based on solder-bond connection technology, has the property *short on fail*. In the event of a fault, it is therefore ensured that the desired short circuit will last. The stack with its clamping devices, rendered image in Figure 7, ensures that the assembly forces are maintained, and the cell cannot expand in the axial direction.

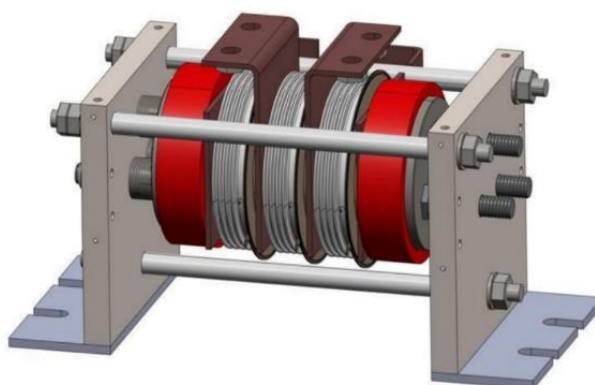

Figure 7: Thyristor-based, 3-phase Crowbar in Δ -connection

This design finds its limits when the energy that has to be handled by the disc is high enough to ignite an arc within the cell. In combination with plasma, which forms in the hermetically sealed cell, the thermal energy of the arc leads to a pressure wave. With a correspondingly high energy content, the pressure wave can detonate the housing.

It is precisely this case rupture that must be avoided. On the one hand, the deformation of the housing can impair the protective function; on the other hand, ceramic cullet represents real shrapnel, which, driven by the shock wave, carries a considerable risk of injury or damage to other system components.

How much energy is required for the destruction depends largely on the structure, size, and thermal capacity of the discs. This gives the engineers the option of selecting a component with reduced size, which only needs to be sufficiently large to remain mechanically intact in the event of a fault.

The same procedure regarding the simulation, now with a disc type N3533ZD220 [4] with a much smaller housing, leads to the result given in Figure 8.

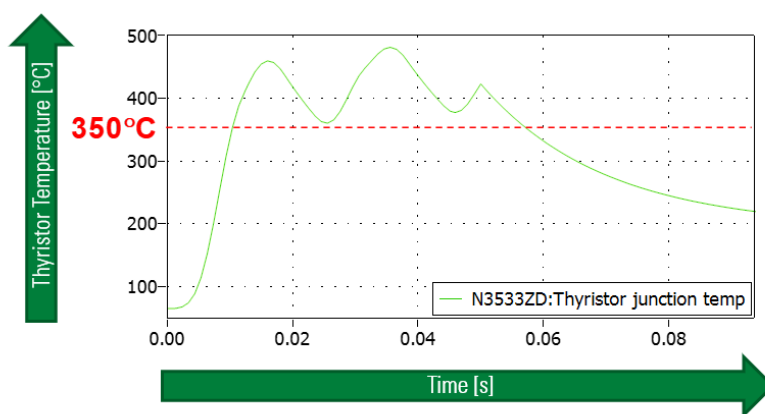

Figure 8: Estimated Junction Temperature Development, N73533ZD

With this component, the maximum tolerable temperature of 350 °C is by far exceeded.

From the result of this estimation, it can be concluded that the thyristor will almost certainly be electrically destroyed. However, the disc cell as such is likely to remain intact. The much smaller component can therefore be considered for the application, especially if the smaller dimensions of the disc help reduce the size of the construction.

For comparison, Figure 9 depicts the scaled comparison of the two components considered.

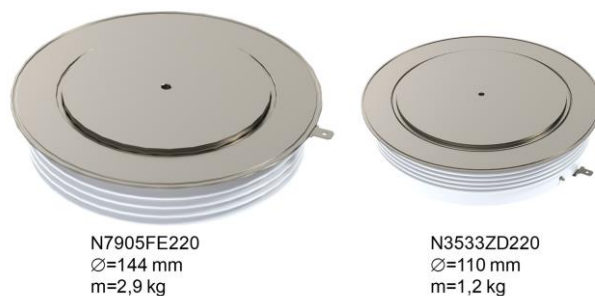

Figure 9: Comparison between the N7905FE220 (resettable) and N3533ZD200 (single use) Components

3. Rupture-enhanced Disc Devices

It is difficult to make a decent estimation about the electrical energy needed to build a pressure-wave, capable of destroying the ceramic housing of a disc.

However, the power involved in this process remains energy per time. Consequently, if the time it takes to set the energy free can be prolonged, the destructive power gets reduced. This was the basic idea behind the rupture-enhanced versions Littelfuse is offering. By adding a PTFE-ring around the die, the process of arcing in the cell is delayed, thus stretching the time to burn the destructive energy. Figure 10 is an exploded view of a cell featuring the rupture-enhanced technology.

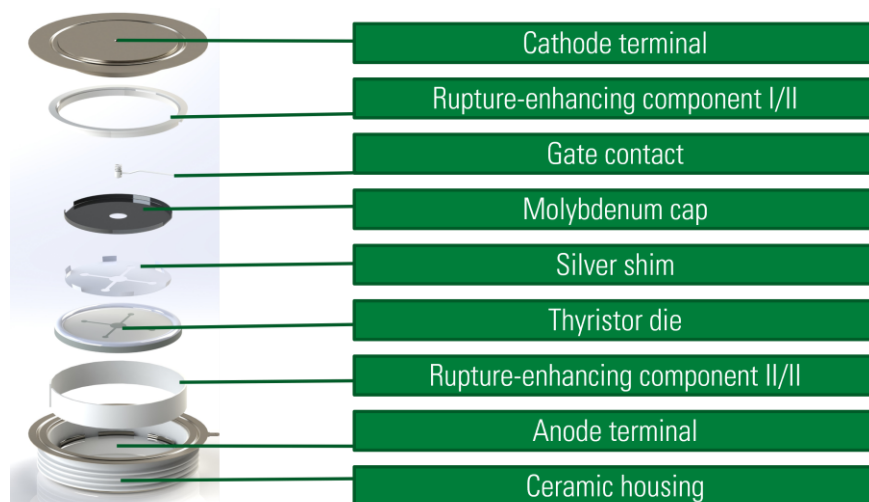

Figure 10: Components of the Rupture-enhanced Package Technology

A general guideline for the rupture-enhanced components like the N3533ZV220, a disc with an electrode diameter of 73 mm and a package height of 26 mm, is an i^2t -value of 25 MA²s and a current value of $I_{RSCM} \leq 110$ kA. As testing for those values can't be done in routine tests due to the destructive nature of the test, the values can't be guaranteed and may even be conservative.

Material returned from a crowbar-testing-site was analyzed in detail after the test was conducted. As expected, the thyristor-dies failed electrically, but no case-rupturing took place. Figure 11 is a photo while opening the destroyed disc and Figure 12 depicts the individual parts of the assembly. The burn-marks on the white PTFE-ring show where arcing started and demonstrate that energy was consumed at these positions. Clearly, no case-rupturing took place, marking the test as successfully completed.



Figure 11: Disc opened for analysis



Figure 12: Disassembled Disc-device

4. Electro-mechanical Considerations

With the enormous currents flowing in the event of a fault, similarly high electromagnetic forces go along. Mostly, these are of no larger concern in electronic designs but at these current-levels, a closer look into it should be done.

Lorenz forces appear in places where currents flow in close proximity. The force that appears between two parallel conductors can be calculated to be:

$$F = \frac{\mu_0 L}{2\pi} \frac{I_1 I_2}{r}$$

In this formula, L represents the conductors' length [m], I_1 and I_2 the current [A] flowing in the two conductors arranged in parallel in a distance r [m]. $\mu_0=4\pi \cdot 10^{-7}$ is the magnetic field constant [Vs/Am]. At levels of 100 kA and conductor distances of $\ll 0.1$ m, 200 kN/m have to be expected, representing 20 tons/m.

In the crowbar application, two dedicated points deserve attention:

- The parts to connect the crowbar to the transformer should be short, to not implement unnecessary stray inductance which would slow down the current build-up. At the same time, close proximity of current-carrying components increases the forces, so increasing the distance is helpful. As space-restrictions also have to be considered, it is advisable to add flexible components in the crowbar's connection path. These can move a short distance during the pulsed current event and therefore reduce mechanical stress to fixed components.
- Looking at the crowbar-stack itself, the closest proximity of conductors appears when current flows through the centered thyristor as sketched in Figure 13.

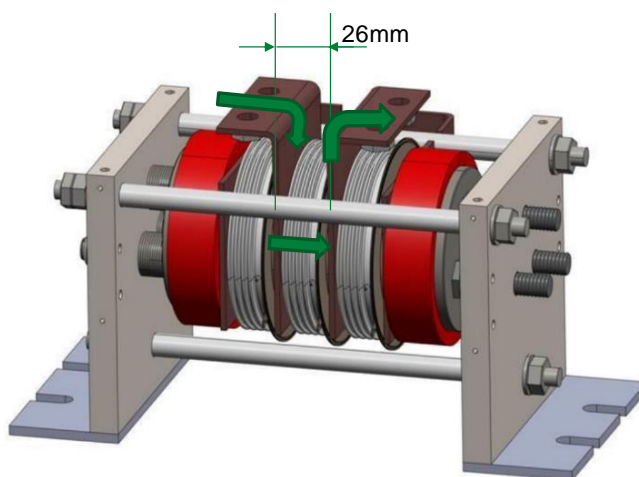

Figure 13: Closest proximity for Parallel Conductors in the Crowbar Stack

Though the effective length of the parallel conductors is just about 0.1m, in combination with the distance of only 0.026m, a force of 8kN or more can occur, pushing the terminal plates apart. The two surrounding thyristors can easily contribute a similar amount, which is why the stack's massive clamping framework is a prerequisite for a reliable design.

Littelfuse customizes and provides the full stack, assembled with decades of experience. Information on how to mount and handle disc devices can be found in the correlating application note [5].

5. Conclusion

Crowbars, when properly designed, are a powerful and reliable tool in fault management. They offer both efficient and effective solutions in handling critical situations and protecting industrial installations. Power electronic crowbars, other than the word indicates, need to be considered carefully and built into the application properly and mindfully.

Littelfuse offers help and guidance in designing and customizing these helpful subsystems and with the rupture-enhanced disc-package also provides a market-leading technology in this area.

References

- [1] Morren, Johan & Haan, S.W.H.. (2007). Short-Circuit Current of Wind Turbines with Doubly Fed Induction Generator. Energy Conversion, IEEE Transactions on. 22. 174 - 180. 10.1109/TEC.2006.889615.
- [2] Noureldeen, Omar. (2012). Behavior of DFIG wind turbines with crowbar protection under short circuit. Int Journal on Electric Computation Science IJECS-IJENS. 12. 32-37.
- [3] Datasheet N7905FE22, Littelfuse, [Issue 1, Dec. 2018](#)
- [4] Datasheet N3533ZD220, Littelfuse, [Issue 4, Feb. 2021](#)
- [5] Littelfuse Application Note, [Mounting and Handling Press-pack Semiconductor Devices](#)

For additional information please visit www.Littelfuse.com/powersemi

Disclaimer Notice - This document is provided by Littelfuse, Inc. ("Littelfuse") for informational and guideline purposes only. Littelfuse assumes no liability for errors or omissions in this document or for any of the information contained herein. Information is provided on an "as is" and "with all faults" basis for evaluation purposes only. Applications described are for illustrative purposes only and Littelfuse makes no representation that such applications will be suitable for the customer's specific use without further testing or modification. Littelfuse expressly disclaims all warranties, whether express, implied or statutory, including but not limited to the implied warranties of merchantability and fitness for a particular purpose, and non-infringement. It is the customer's sole responsibility to determine suitability for a particular system or use based on their own performance criteria, conditions, specific application, compatibility with other components, and environmental conditions. Customers must independently provide appropriate design and operating safeguards to minimize any risks associated with their applications and products.

Littelfuse products are not designed for, and shall not be used for, any purpose (including, without limitation, automotive, military, aerospace, medical, life-saving, life-sustaining or nuclear facility applications, devices intended for surgical implant into the body, or any other application in which the failure or lack of desired operation of the product may result in personal injury, death, or property damage) other than those expressly forth in applicable Littelfuse product documentation. Littelfuse shall not be liable for any claims or damages arising out of products used in applications not expressly intended by Littelfuse as set forth in applicable Littelfuse documentation.

Read complete Disclaimer Notice at www.littelfuse.com/disclaimer-electronics