

Auxiliary Switch

HCD Series

1 NO / NC • SPDT / (2) SPDT circuit



Description

The HCD auxiliary switch is designed as an accessory to a 3-pole / 4-pole contactor and used to switch an auxiliary load below 10 amperes.

The HCD Series auxiliary switch are compliant with the A2L refrigerant requirement of UL Category Control Number (CCN) LZGH2/LZGH8 for Annex JJ of UL 60335-2-40.

Features & Benefits

FEATURES	BENEFITS
One model fits all Hartland Controls 3-pole / 4-pole contactors	Reducing the need for multiple switch models

Applications

- HVAC/R

Specifications

Power Terminal Connections	Single Unit Interlock Configuration (One on Each Side – Max of Two), SPDT Circuit: 0.250" quick connects; Single Unit Interlock Configuration (One on Each Side – Max of Two ¹), 1 NO / NC Circuit: #6-32 screw terminals Single Unit Interlock Configuration (One on Each Side – Max of Two ¹), 1 NO / NC Circuit: 0.250" quick connects
Arrangement	Single Unit Interlock Configuration: 1 NO / NC (break before make); SPDT Circuit (One switch per Side): SPDT: SPDT Circuit (Two Switches per Side): (2) SPDT
Mounting Method	Chassis mount

Certification & Compliance²

CERTIFICATION	CERTIFICATION FILE NUMBER	VOLTAGE RATING
UL 508	File No. E227250	600 V AC version only
UL 60335-2-40 (CCN LZGH2 /CCN LZGH8)	File No. E227250	600 V AC version only
CSA	221260 (1456104)	600 V AC version only

¹Please contact Littelfuse if using 2 Auxiliary Switches on both sides of the contactor when using 208 VAC coil voltage.

²Contact Littelfuse for specific agency approved rating.

Auxiliary Switch

HCD Series

Ordering Information

CATALOG NO.	ORDERING NO.	CURRENT RATING	VOLTAGE RATING	SPECIAL FUNCTION	CONTACT FORM PER CIRCUIT	WEIGHT
CON-AUX300V-1	HCDY1C300VQ850	10 A	250 V AC	SPDT Circuit; one switch per DP contactor side (max of two)	SPDT	0.1 Lb
CON-AUX300V-2	HCDY2C300VQ850	10 A	250 V AC	SPDT Circuit; two switches per DP contactor side (max of two)	(2) SPDT	0.1 Lb
CON-AUX600V-1	HCDY1Z600VC850	5 A ³	600 V AC	Single Unit interlock configuration; one per DP contactor side (max of two ¹)	1 NO / NC	0.1 Lb

The Catalog Number serves solely as an identifier. When placing an order, please use ordering number.

Dimensions inches (mm)

SPDT

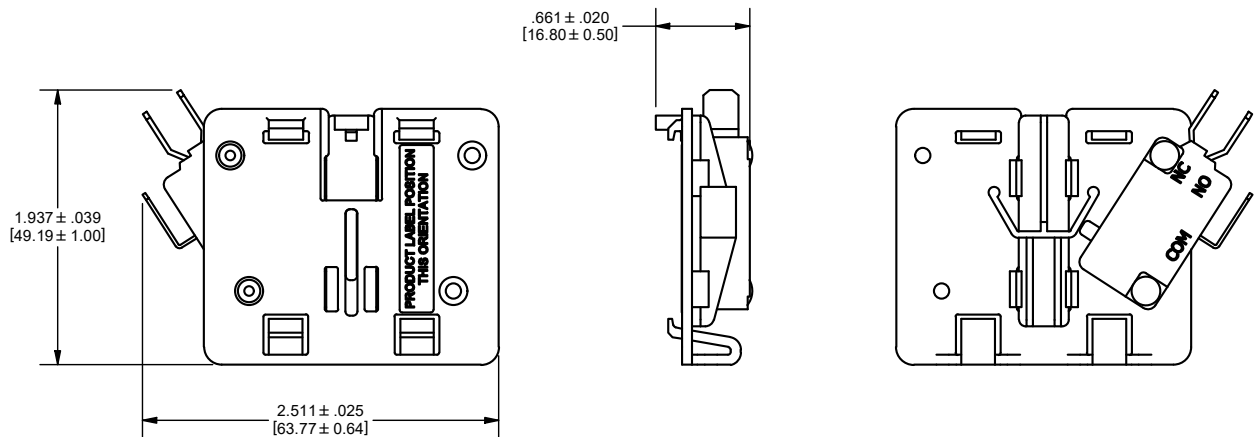

¹Please contact Littelfuse if using 2 Auxiliary Switches on both sides of the contactor when using 208 VAC coil voltage.

³This Auxiliary Switch has a B600 rating. The B600 rating is defined by NEMA ICS 5: Industrial Control and Systems, Control Circuit and Pilot Devices standard.

Auxiliary Switch HCD Series

(2) SPDT

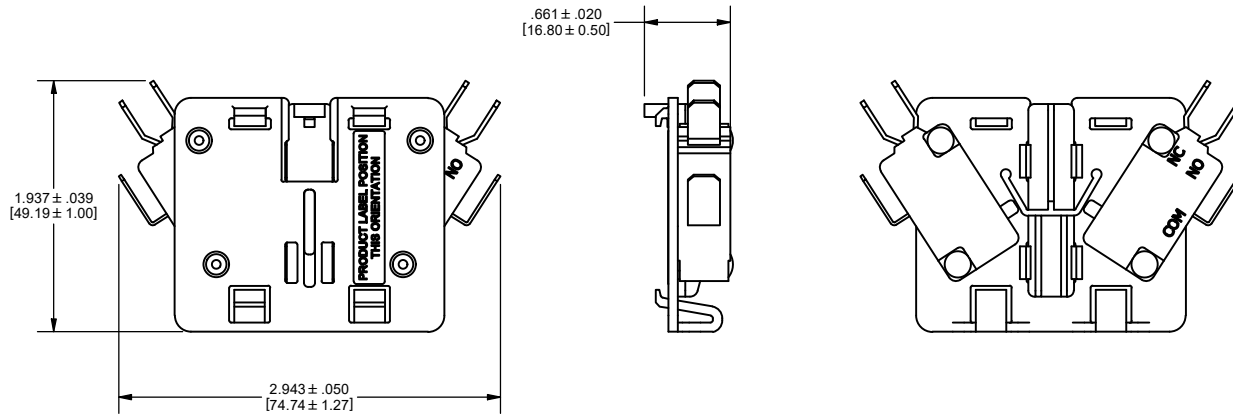

1 NO / NC

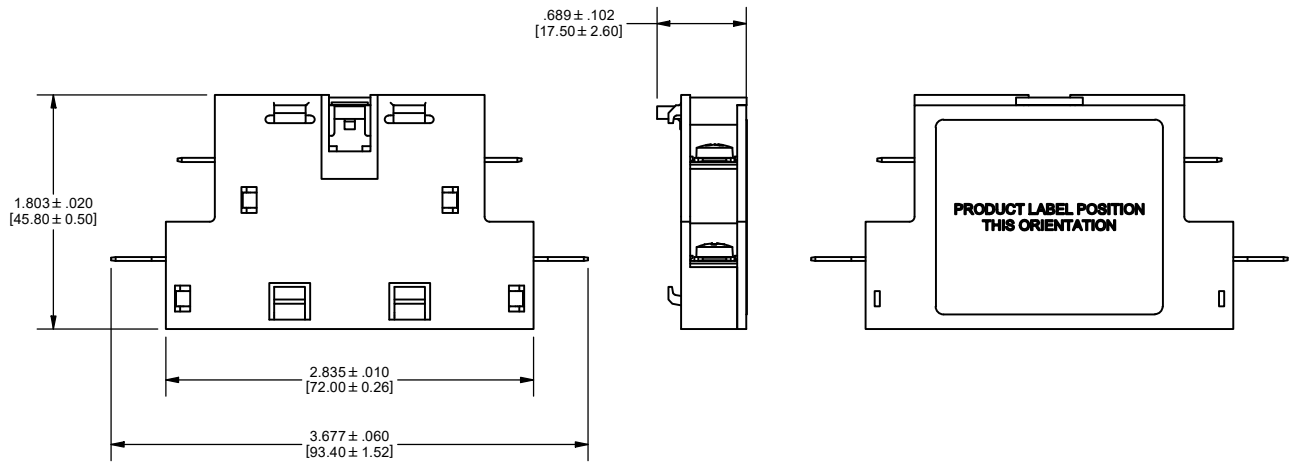

Disclaimer Notice – Information furnished is believed to be accurate and reliable. However, users should independently evaluate the suitability of and test each product selected for their own applications. Littelfuse products are not designed for, and may not be used in, all applications. Read complete Disclaimer Notice at www.littelfuse.com/product-disclaimer.