

REVISIONS				
ZONE	REV.	DESCRIPTION	DATE	APPROVED
	A	GCF 523963 NEW RELEASE	28/Jun/2021	EJIN
	B	524752ECC-LATCH PN WAS 883-088	1/20/2022	EJIN

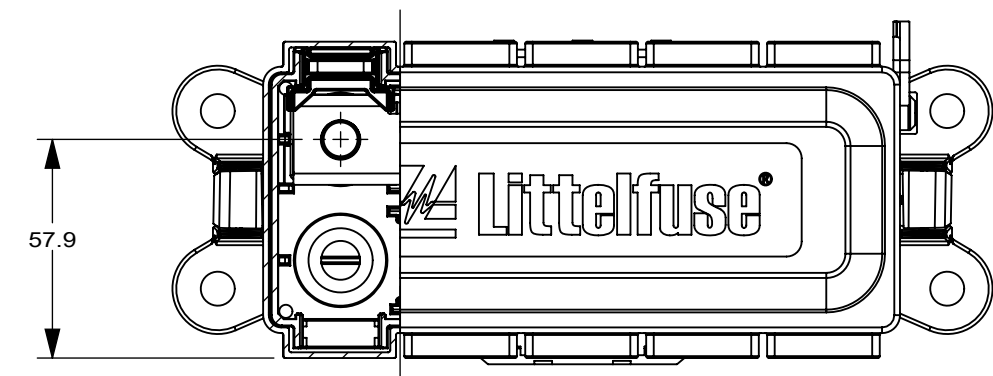

SECTION A-A

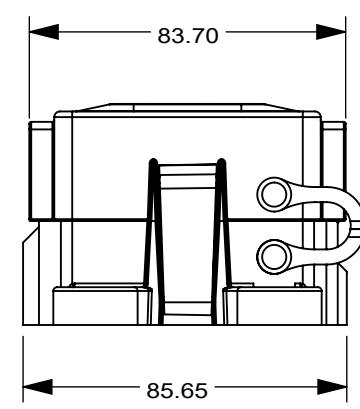
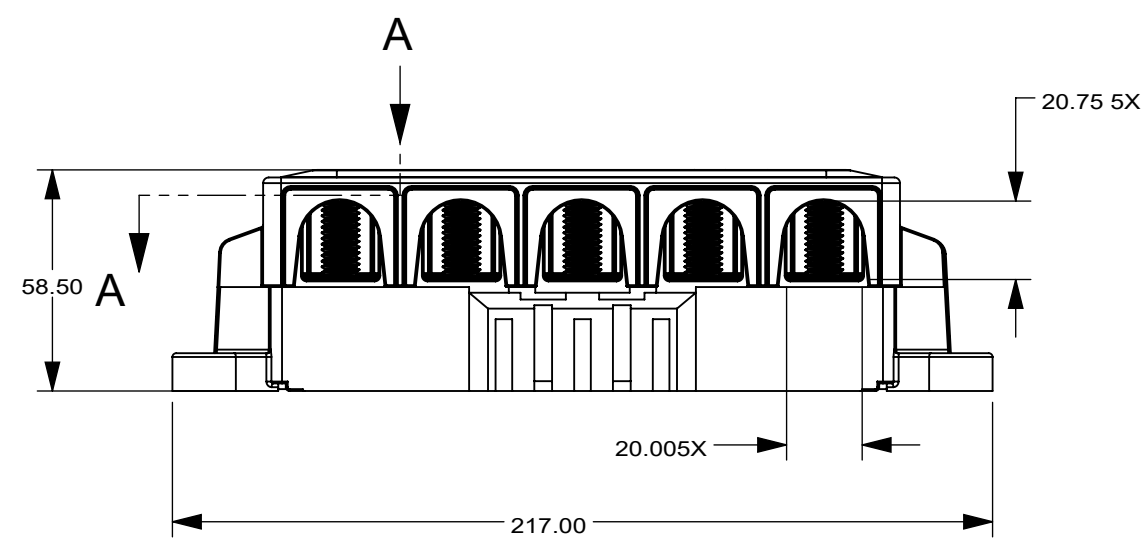
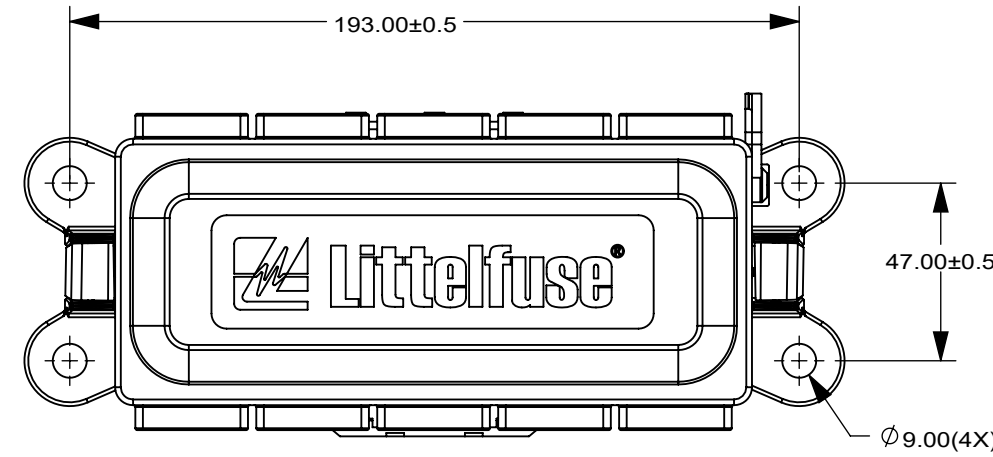
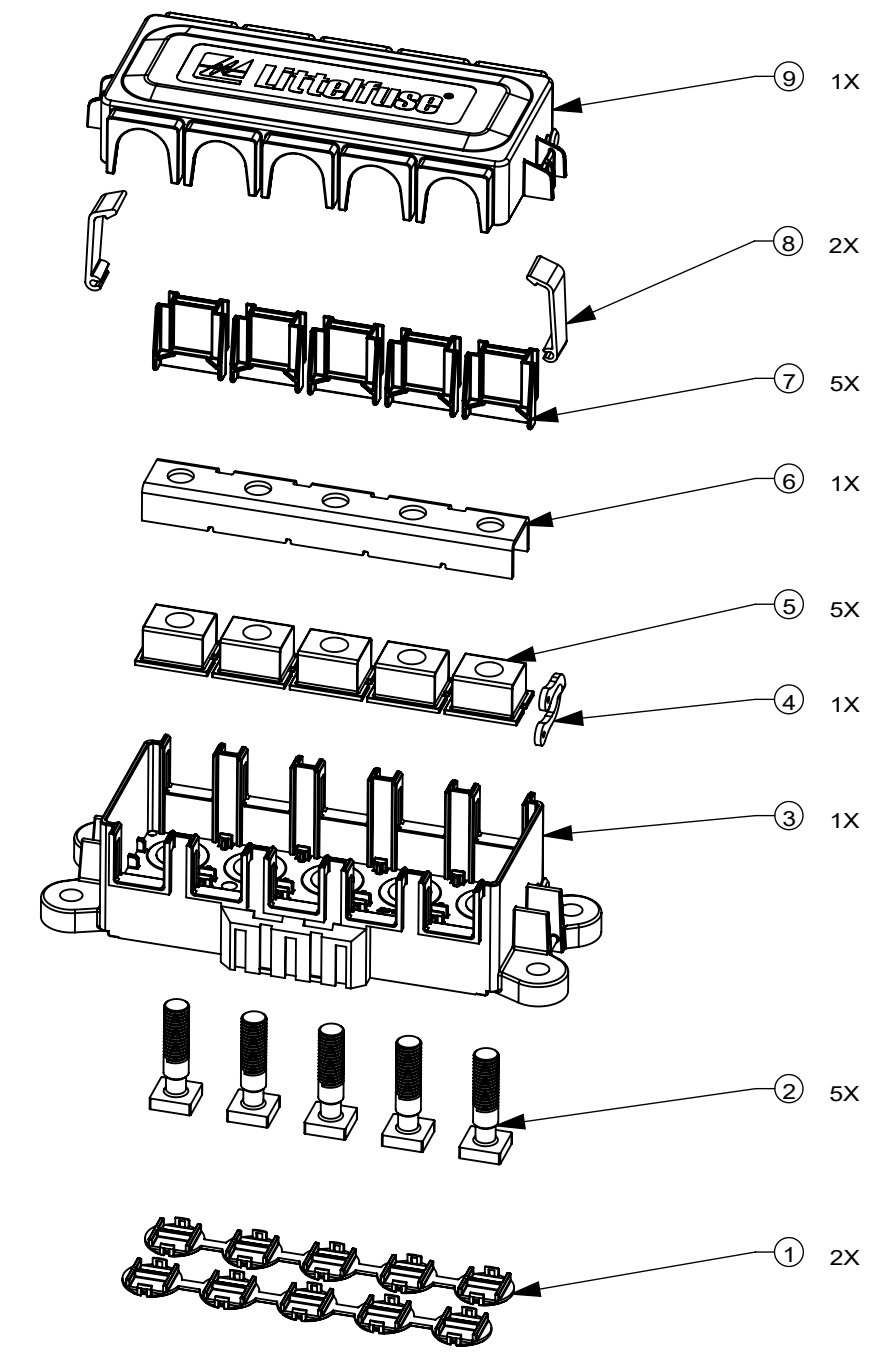
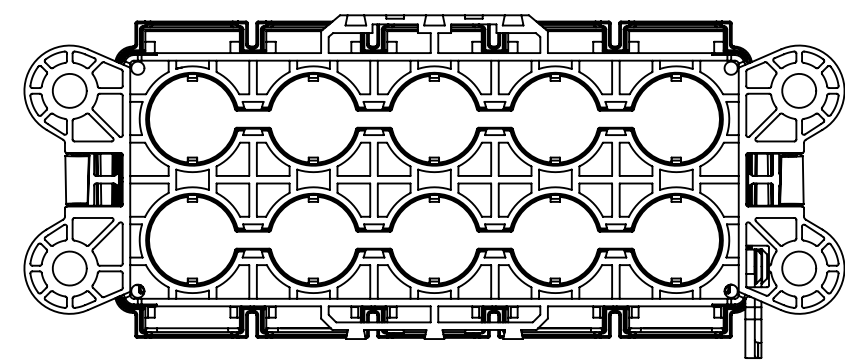

NO.	COMPONENT NO.	COMPONENT NAME	QTY/M	U/M
9	873-716	COVER	1	EA
8	(B) 883-029	LATCH	2	EA
7	901-520	DUST COVER	5	EA
6	882-927-5	U SHAPE BUS BAR	1	EA
5	901-722	SINGLE SUPPORT	5	EA
4	890009470	TETHER	1	EA
3	868-967	BASE	1	EA
2	908-077	M10 STUD	5	EA
1	883-094	BOTTOM CAP	2	EA

LIMIT DIMENSIONS OF PLASTIC MOLDED PARTS FOR NOMINAL SIZE RANGES PER ISO IN LITTELFUSE CVP-NPD20-0002, DIMENSIONS MM												
1 to 3	>3 to 6	>6 to 10	>10 to 18	>18 to 30	>30 to 50	>50 to 80	>80 to 120	>120 to 180	>180 to 250	>250 to 315	>315 to 400	ANGLE
±0.08	±0.11	±0.14	±0.17	±0.20	±0.23	±0.36	±0.50	±0.58	±0.65	±0.70	±0.78	NONE

SURFACE PROFILE DIMENSIONS OF PLASTIC MOLDED PARTS FOR NOMINAL SIZE RANGES PER ISO IN LITTELFUSE CVP-NPD20-0002, DIMENSIONS MM												
0.50	0.50	0.50	0.50	0.50	0.50	0.50	0.50	1.0	2.0	4.0	4.0	

PER CHNPD20-008 PROCEDURE		
●	FIT/ FUNCTION CRITICAL CHARACTERISTICS	
<S>	SAFETY/ COMPLIANCE CRITICAL CHARACTERISTICS SYMBOL	
CPK	DENOTES CPK DIMENSIONS MINIMUM CPK VALUE	
ST	DENOTES A CHARACTERISTIC THAT PROVIDES AN INDICATION OF PROCESS PERFORMANCE PROCEDURE FOR MEASUREMENT AND TRACKING TO BE DEFINED IN LITTELFUSE INSPECTION INSTRUCTIONS	
CP	DENOTES CP DIMENSIONS. -MINIMUM CP VALUE MUST BE WITHIN THE DIMENSIONAL LIMITATIONS SHOWN ON DRAWING AND INITIALLY LOCATED TO ALLOW FOR MAXIMUM TOOL LIFE	

- NOTES:
- MATERIALS:
 BASE/COVER: BLACK FR530
 BUS BAR: C1100 Sn PLATED
 DUST COVER: GREEN SILICON RUBBER
 TETHER: BLACK SILICON RUBBER
 STUD: STEEL Ni/Fe ALLOY PLATED
 BOTTOM CAP: BLUE PA66
 LATCH: YELLOW POM
 SUPPORT: BLACK BAKELITE
 - MAX. MAIN INPUT: 400A
 - OPERATING TEMPERATURE RANGE: -40°C TO 105°C
 - M8 MOUNTING TORQUE: 10±2 Nm
 - MAX. WIRE SIZE 105 sqmm OR AWG 4/0

DRAWN	VLI	DATE	7/7/2021	<p>Littelfuse Expertise Applied Answers Delivered</p>
CHECKED	FYUE	DATE	7/7/2021	
FORM NO: CVP-PE40-0005 REV B THIRD ANGLE PROJECTION				
TITLE			FHZ 5-STUD GROUND BOX	
DO NOT SCALE DRAWING		SCALE	1:2	REV. B

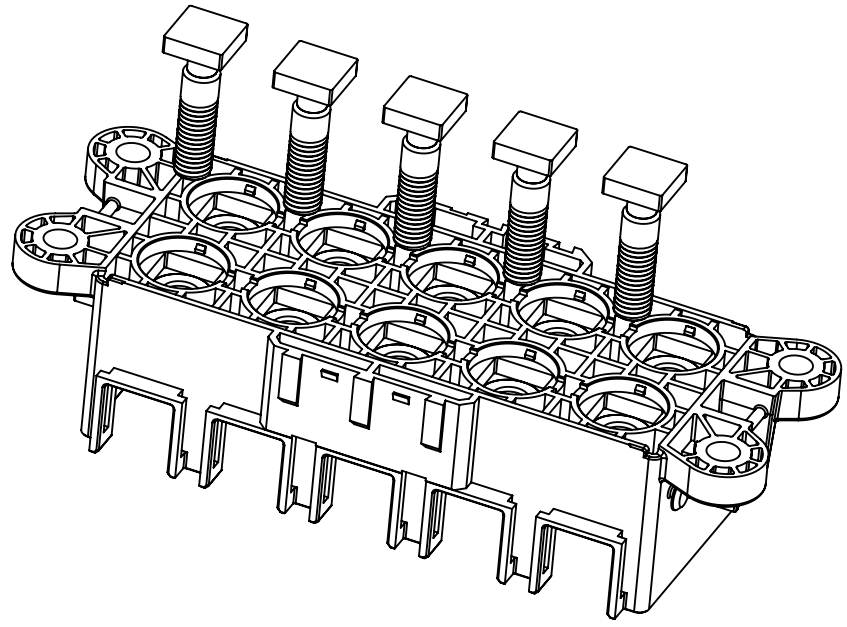

PUT 5PCS M10 STUD (908-077) INTO THE BOTTOM HOLE OF BASE (868-967)

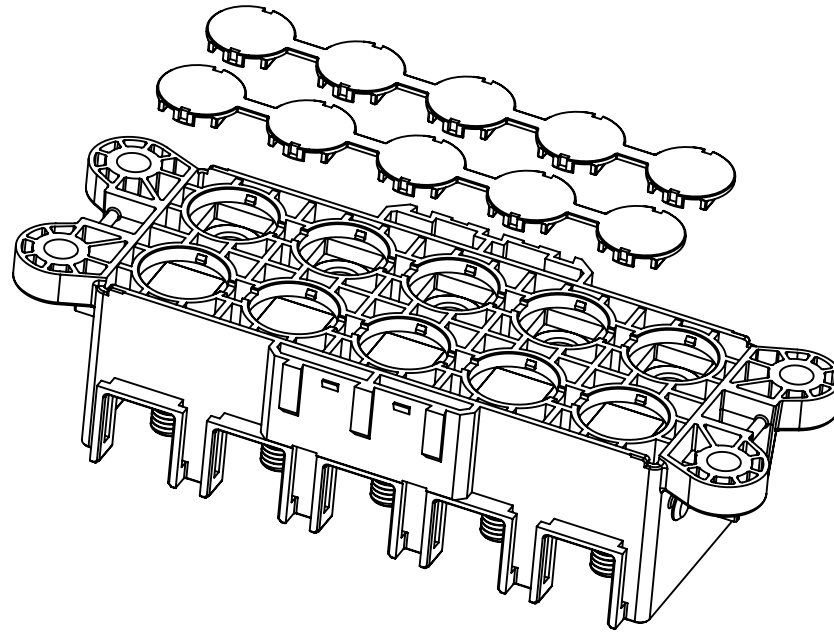

ASSEMBLY 2PCS BOTTOM CAP (883-094) ON BASE TO FIX STUDS

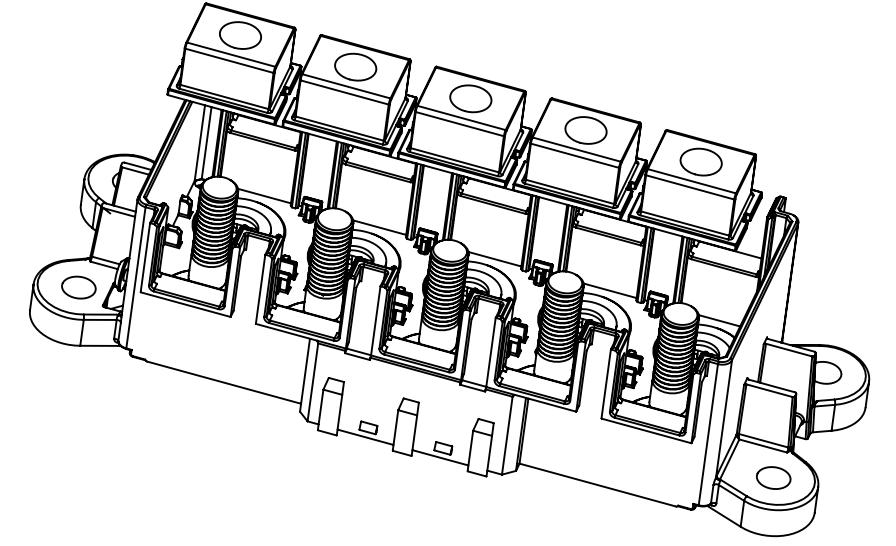

ASSEMBLY 5PCS SINGLE SUPPORT (901-722) ON BASE THROUGH STUDS

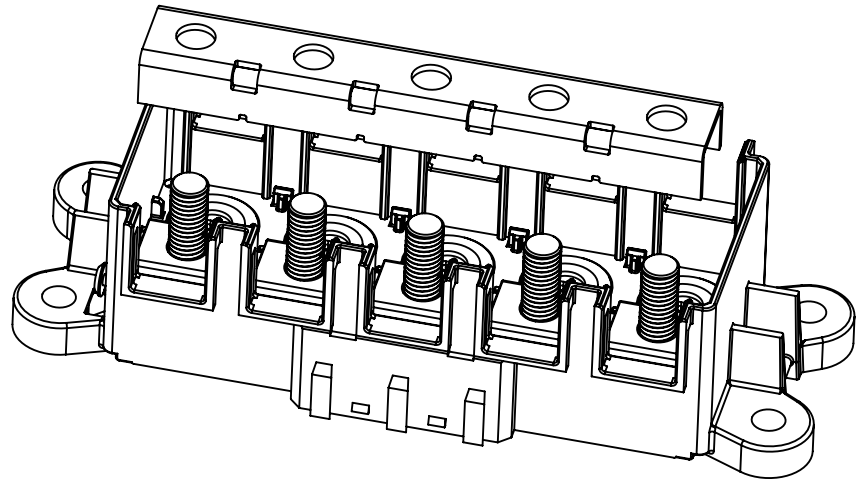

PUT 1PC U SHAPE BUS BAR (882-927-5) ON SUPPORT

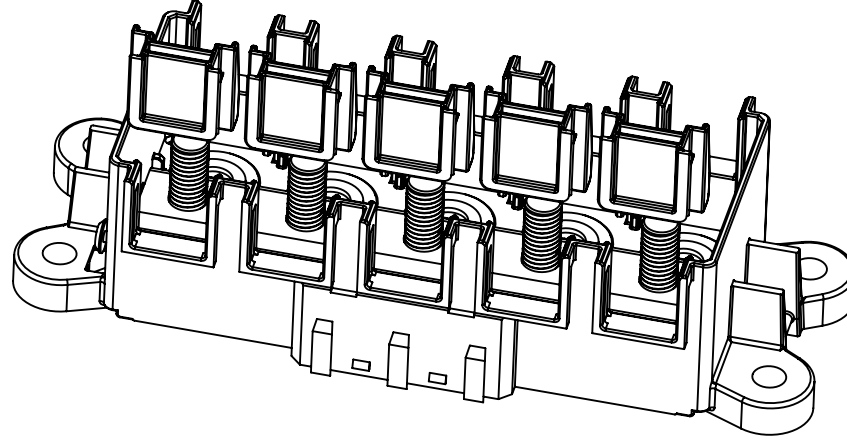

ASSEMBLY 5PCS DUST COVER (901-520) ON BASE

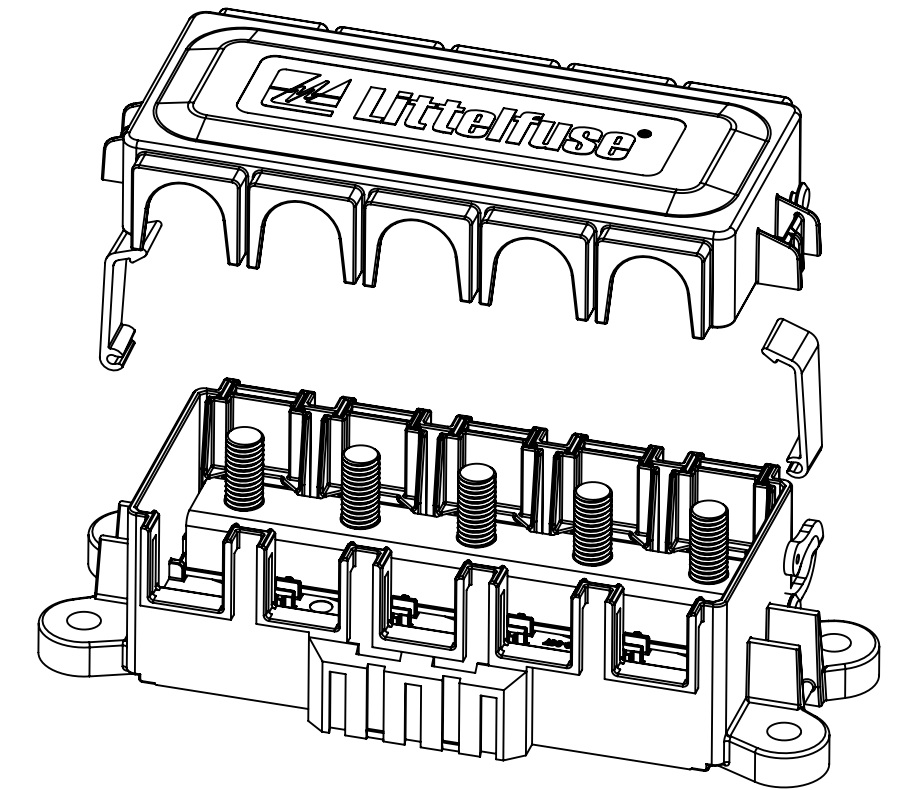

ASSEMBLY 2PCS LATCH (883-029), 1PC TETHER (890009470) AND 1 PC COVER (873-716) ON BASE

LIMIT DIMENSIONS OF PLASTIC MOLDED PARTS FOR NOMINAL SIZE RANGES PER ISO IN LITTELFUSE CVP-NPD20-0002, DIMENSIONS mm											
1 to 3	>3 to 6	>6 to 10	>10 to 18	>18 to 30	>30 to 50	>50 to 80	>80 to 120	>120 to 180	>180 to 250	>250 to 315	ANGLE
±0.08	±0.11	±0.14	±0.17	±0.20	±0.23	±0.36	±0.50	±0.58	±0.65	±0.70	NONE
SURFACE PROFILE DIMENSIONS OF PLASTIC MOLDED PARTS FOR NOMINAL SIZE RANGES PER ISO IN LITTELFUSE CVP-NPD20-0002, DIMENSIONS mm											
0.50	0.50	0.50	0.50	0.50	0.50	0.50	0.50	1.0	2.0	4.0	4.0
DIMENSIONS ARE SHOWN IN MILLIMETERS. DIMENSIONS AND TOLERANCES ARE DEFINED ACCORDING TO ANSI/ASME Y14.5-1994.											
PER CH-NPD20-008 PROCEDURE	●	FIT/ FUNCTION CRITICAL CHARACTERISTICS									
	<S>	SAFETY/ COMPLIANCE CRITICAL CHARACTERISTICS SYMBOL									
	CPK	DENOTES CPK DIMENSIONS MINIMUM CPK VALUE									
	ST	DENOTES A CHARACTERISTIC THAT PROVIDES AN INDICATION OF PROCESS PERFORMANCE PROCEDURE FOR MEASUREMENT AND TRACKING TO BE DEFINED IN LITTELFUSE INSPECTION INSTRUCTIONS									
CP	DENOTES CP DIMENSIONS, -MINIMUM CP VALUE MUST BE WITHIN THE DIMENSIONAL LIMITATIONS SHOWN ON DRAWING AND INITIALLY LOCATED TO ALLOW FOR MAXIMUM TOOL LIFE										
NAME		DATE									
DRAWN		VLI		7/7/2021							
CHECKED		FYUE		7/7/2021							
FORM NO.		CVP-PE40-0005 REV B		THIRD ANGLE PROJECTION							
TITLE		FHZ 5-STUD GROUND BOX									
DO NOT SCALE DRAWING		SCALE 1:2		SIZE C		DWG. NO.		FHZ1008Z		REV. B	
										SHEET 2 OF 2	

