

THIS DRAWING AND THE INFORMATION CONTAINED WITHIN IT ARE CONFIDENTIAL AND MAY NOT BE COPIED OR DISCLOSED WITHOUT THE WRITTEN PERMISSION OF LITTELFUSE.

| REVISIONS | | | | |
|-----------|--------------------------------|-----------|-------------|----------|
| REV. | DESCRIPTION | DATE | DESIGNED | APPROVED |
| A | First issue of outline drawing | 03-Aug-20 | L.Dal Molin | M.Tinto |

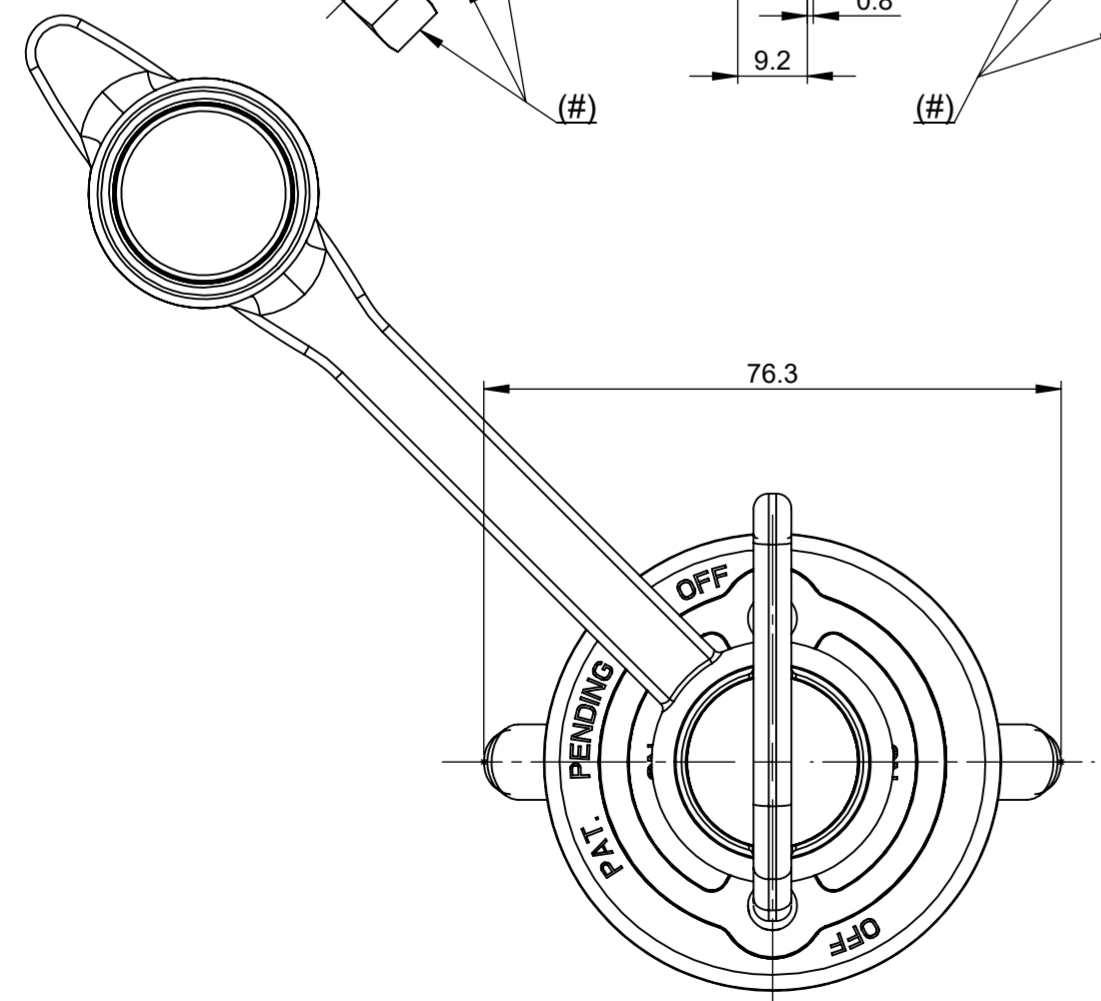

OPEN CONTACT ("OFF")
(View without flat washers - washer springs - nuts)

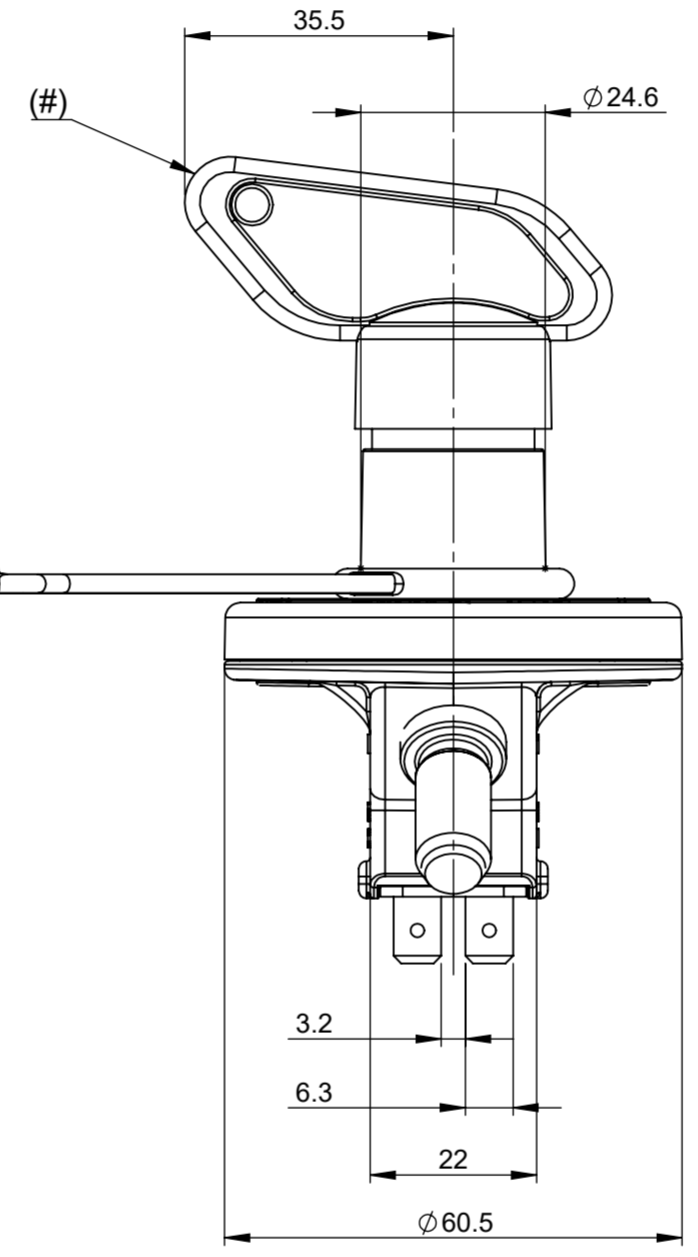
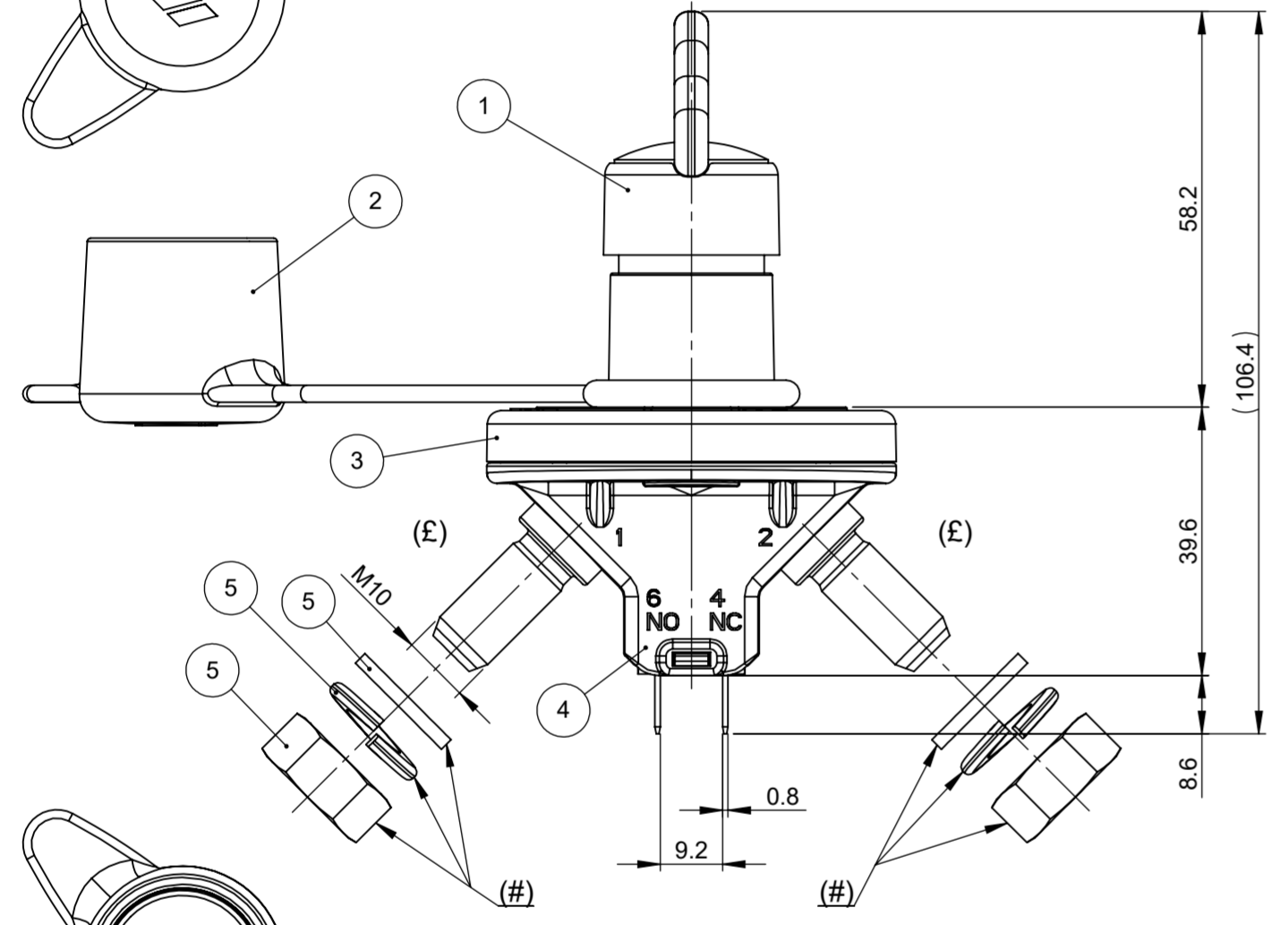
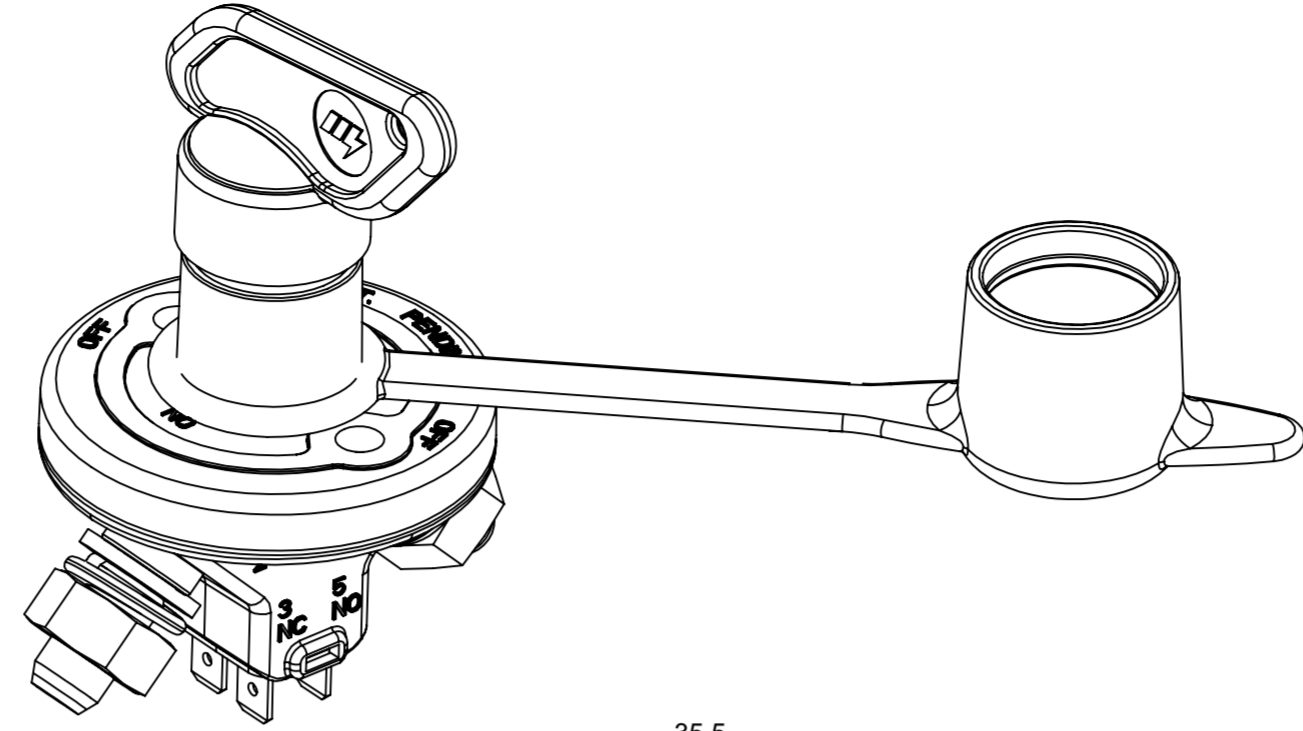
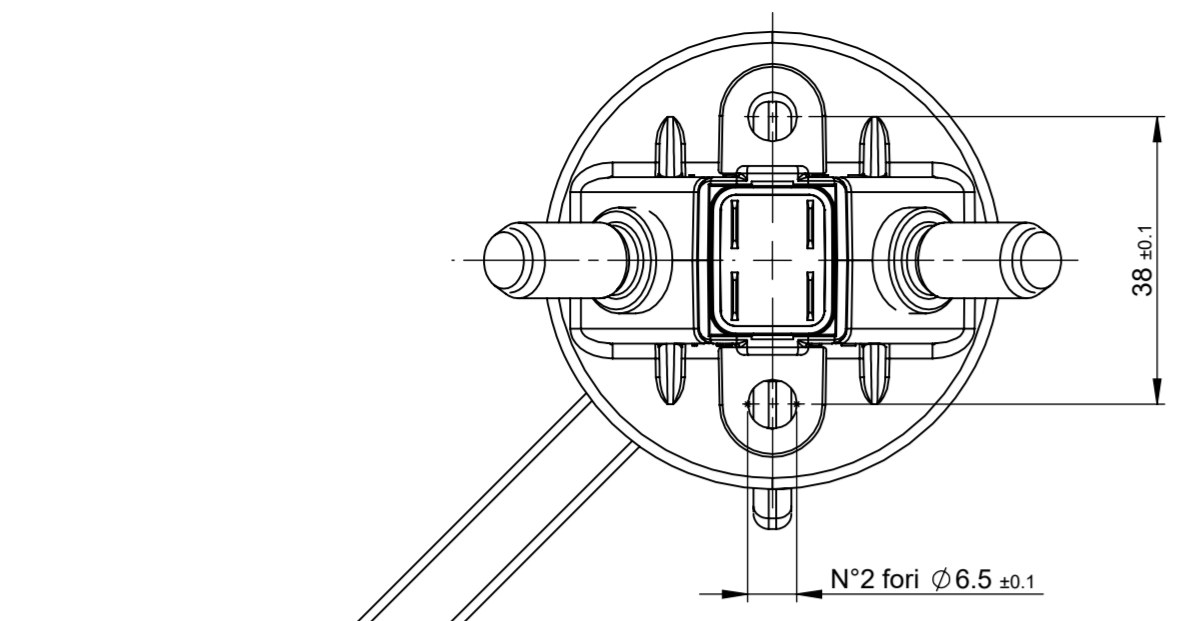
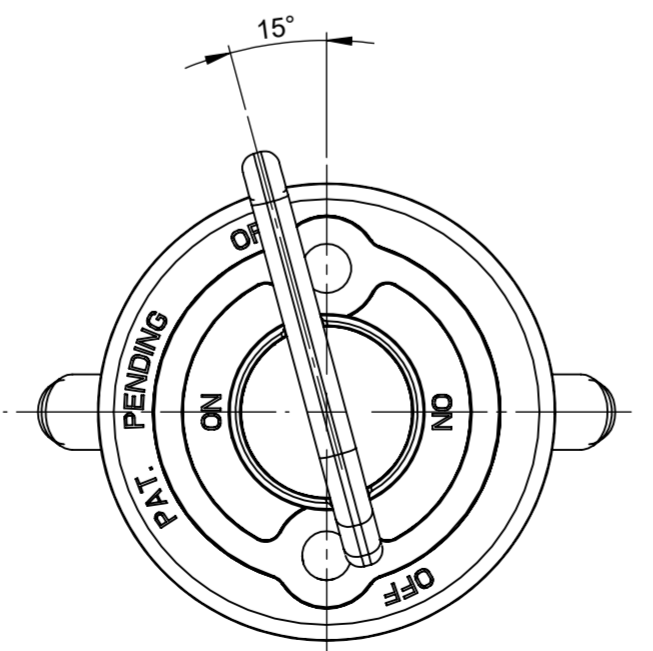

POSITION TO INSERT/REMOVE THE KEY
(View without flat washers - washer springs - nuts, and protection cap)

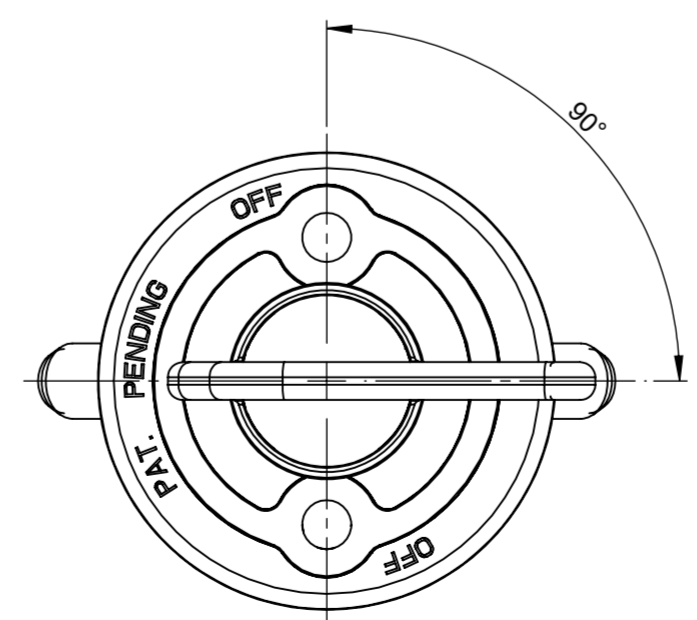

CLOSED CONTACT ("ON")
(View without flat washers - washer springs - nuts and protection cap)

CHARACTERISTICS

- Nominal voltage: 12-24V
- Maximum continuous current main contacts: 150A
- Maximum current main contacts short time: 1500A x 5s @23±5°C
- Maximum continuous current auxiliary contacts: 5A
- Maximum current auxiliary contacts short time: 120A x 5s @23±5°C
- M10 nuts tightening torque: 20±2 Nm

- (£) Marking of manufacturing date in accordance with Littelfuse Standard, indifferently on the side indicated in the drawing or on the opposite one
- Test the device in accordance with Littelfuse Specification

- (#) Components supplied not assembled: key, 2 M10 nuts, 2 flat washers and 2 washer springs

ASSEMBLY KEY

To assemble the key, insert it and turn it clockwise of 15° taking the device in state Switched OFF; to remove it, with the device in state Switched OFF turn it counterclockwise of 15° and extract it

OPERATION

- To close (switch on) the contacts: turn clockwise the key of 90°
- To open (switch off) the contacts: turn counterclockwise the key of 90°

| POS. | P/N | DESCRIPTION | MATERIAL | Q.TY | U/M |
|------|----------|---------------------|-----------|------|-----|
| 5 | | Kit for Bms IGC/175 | | 1 | EA |
| 4 | | Lower body complete | | 1 | EA |
| 3 | | Upper body with key | Polyamide | 1 | EA |
| 2 | 00902700 | Cap eyelet for key | Rubber | 1 | EA |
| 1 | 00902200 | Key complete | Polyamide | 1 | EA |

| DIMENSIONS AND TOLERANCES IN MILLIMETERS, DEFINED ACCORDING TO ISO 1101-2017. | | | | | | |
|---------------------------------------------------------------------------------------------------------------------------------------------------------------------------|------|-----------|--------|-------------------------------------------|-------|-------|
| linear dimensions | | | | | | |
| 0,5 | >3 | >6 | >30 | >120 | >400 | >1000 |
| 3 | 6 | 30 | 120 | 400 | 1000 | 2000 |
| ±0,2 | ±0,3 | ±0,5 | ±0,8 | ±1,2 | ±2 | ±3 |
| angle (for range of lengths) | | | | | | |
| up to 10 | >10 | >50 | >120 | >400 | >1200 | >2000 |
| ±1°30' | ±1° | ±0°30' | ±0°15' | | | |
| ● FIT/ FUNCTION CRITICAL CHARACTERISTICS SYMBOL | | | | | | |
| <S> SAFETY/ COMPLIANCE CRITICAL CHARACTERISTICS SYMBOL | | | | | | |
| CPK DENOTES CPK DIMENSIONS MINIMUM CPK VALUE | | | | | | |
| ST DENOTES A CHARACTERISTIC THAT PROVIDES AN INDICATION OF PROCESS PERFORMANCE.PROCEDURE FOR MEASUREMENT AND TRACKING TO BE DEFINED IN LITTELFUSE INSPECTION INSTRUCTIONS | | | | | | |
| CP DENOTES CP DIMENSIONS. MINIMUM CP VALUE MUST BE WITHIN THE DIMENSIONAL LIMITATIONS SHOWN ON DRAWING AND INITIALLY LOCATED TO ALLOW FOR MAXIMUM TOOL LIFE | | | | | | |
| NAME | | DATE | | Expertise Applied Answers Delivered | | |
| DRAWN: L.Dal Molin | | 03-Aug-20 | | | | |
| CHECKED: - | | - | | TITLE | | |
| - | | - | | IGC/175-CD | | |
| - | | - | | SIZE: A2 | | |
| - | | - | | DWG. NO. OL-08080400 | | |
| - | | - | | OUTLINE REV. A | | |
| DO NOT SCALE DRAWING | | SCALE 1:1 | | SHEET 1 OF 1 | | |

SAP drawing number:

Material and treatments: