

05931300 & 05931600 RELAYS

12V/24V • Time-delay relays • ADR applications



05931300



05931400



05931500



05931600

Description

This delay-off timer relays are designed to delay the opening of the ADR battery switch installed on vehicles approved for EURO 4 EURO 5 and later.

All industrial vehicles produced from 2006 onwards, in order to comply with the pollution regulations, are equipped with the SCR (Selective Catalytic Reduction) system for reducing emissions in exhaust gases using an urea chemical agent (eg. Ad-Blue). This system requires a cleaning cycle of variable life depending on the vehicle, after the engine has been switched off. It is therefore necessary to supply power to the electrical system for about 3 minutes after the vehicle is stopped by installing these relays that delay the isolation of the batteries.

Features and Benefits

- All the relays switches are available in version 12V and 24V
- This timer relay work to delay intervention of 3 min or 6 min.

Specifications Overview

Voltage: 12V/24V

Applications

- ADR Trucks approved EURO 4, EURO 5 and later.

Web Resources

Download technical resources at:
littelfuse.com/relays

Electrical diagram

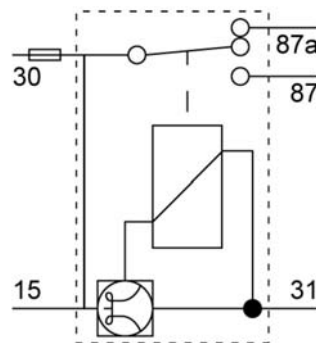

Mounting diagram

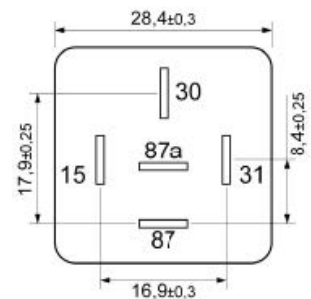

Dimensions in millimeters

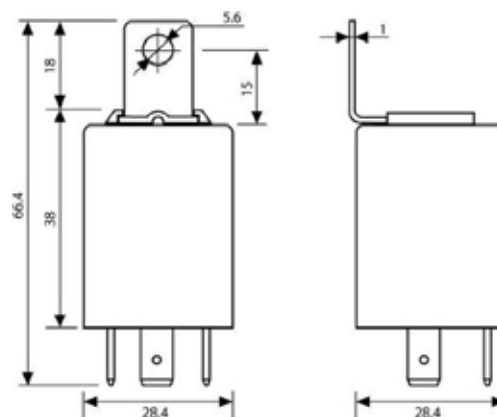

Ordering Information

PART NUMBER	VOLTAGE	CONTINUOUS CURRENT	TIME DELAY RANGE
05931300	12V	20A	3 min.
05931400	24V	10A	3 min.
05931500	12V	20A	6 min.
05931600	24V	10A	6 min.