

COVER PART	COVER OPENING POSITION	MEGAFUSE IN HOLDER
A	A C	0298175.ZXEH
B	A C E	0298175.ZXEH
C	A C E	0298500.ZXH

LTR	DATE	REVISION	CHK	APD
A	11/09/13	509475GCA - RELEASED	OPL	
B	06/19/14	510654ECA-CHANGE DIMENSION FROM 38.2 TO 38.5 ADD REF	OPL	

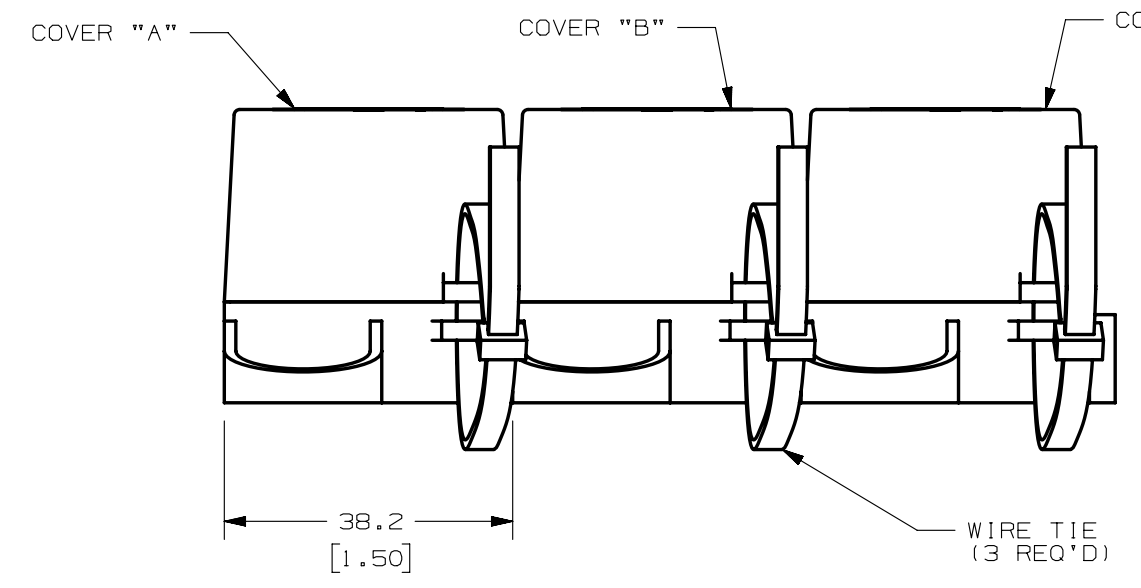
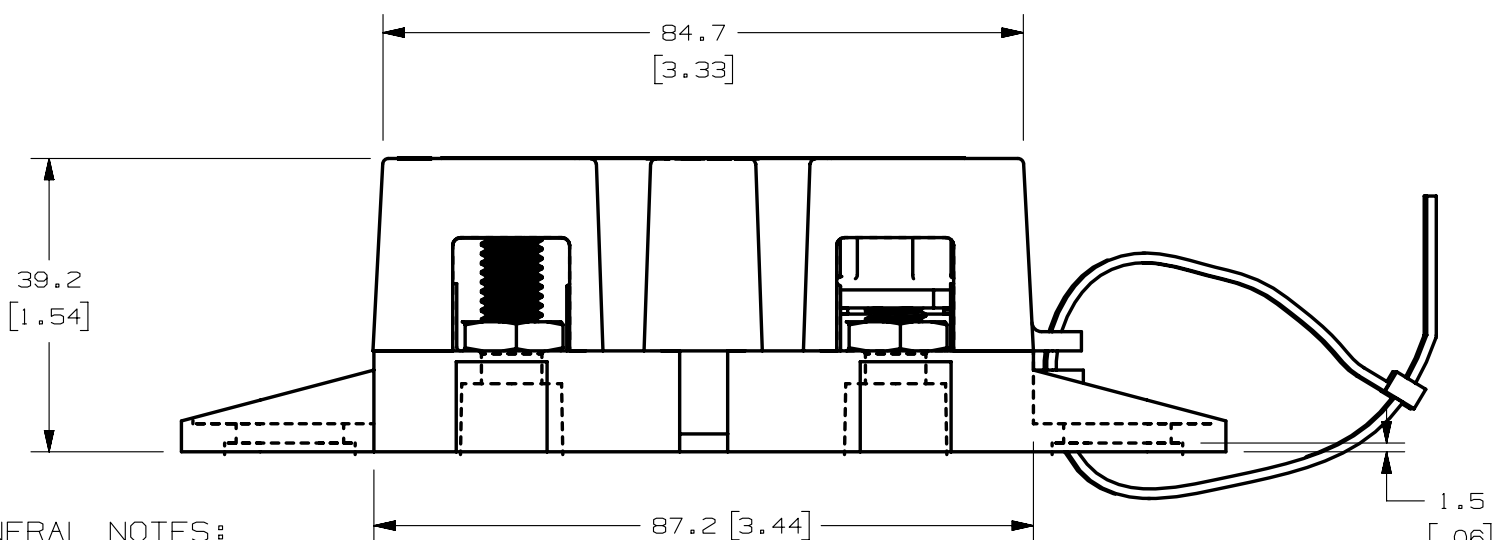
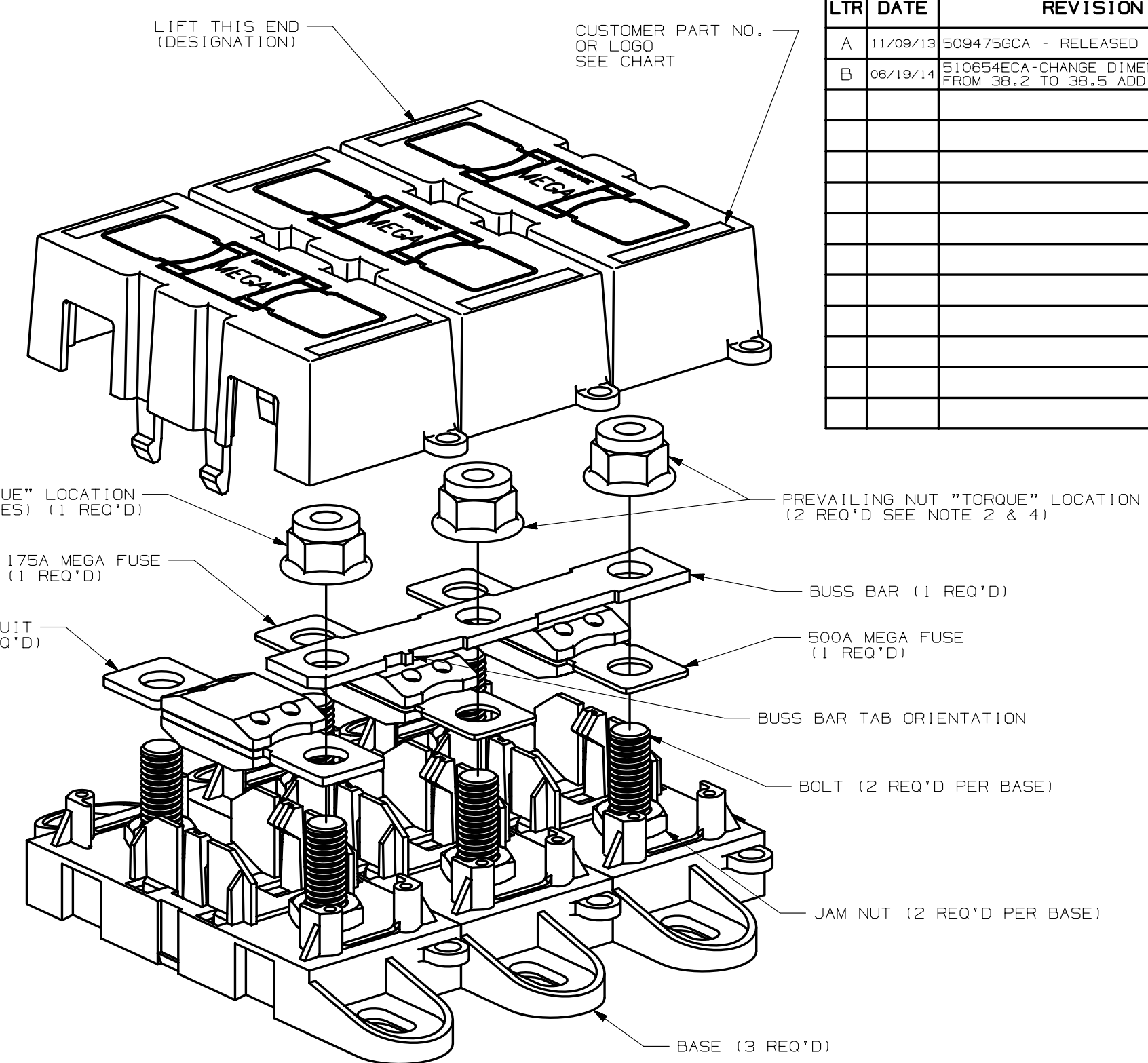
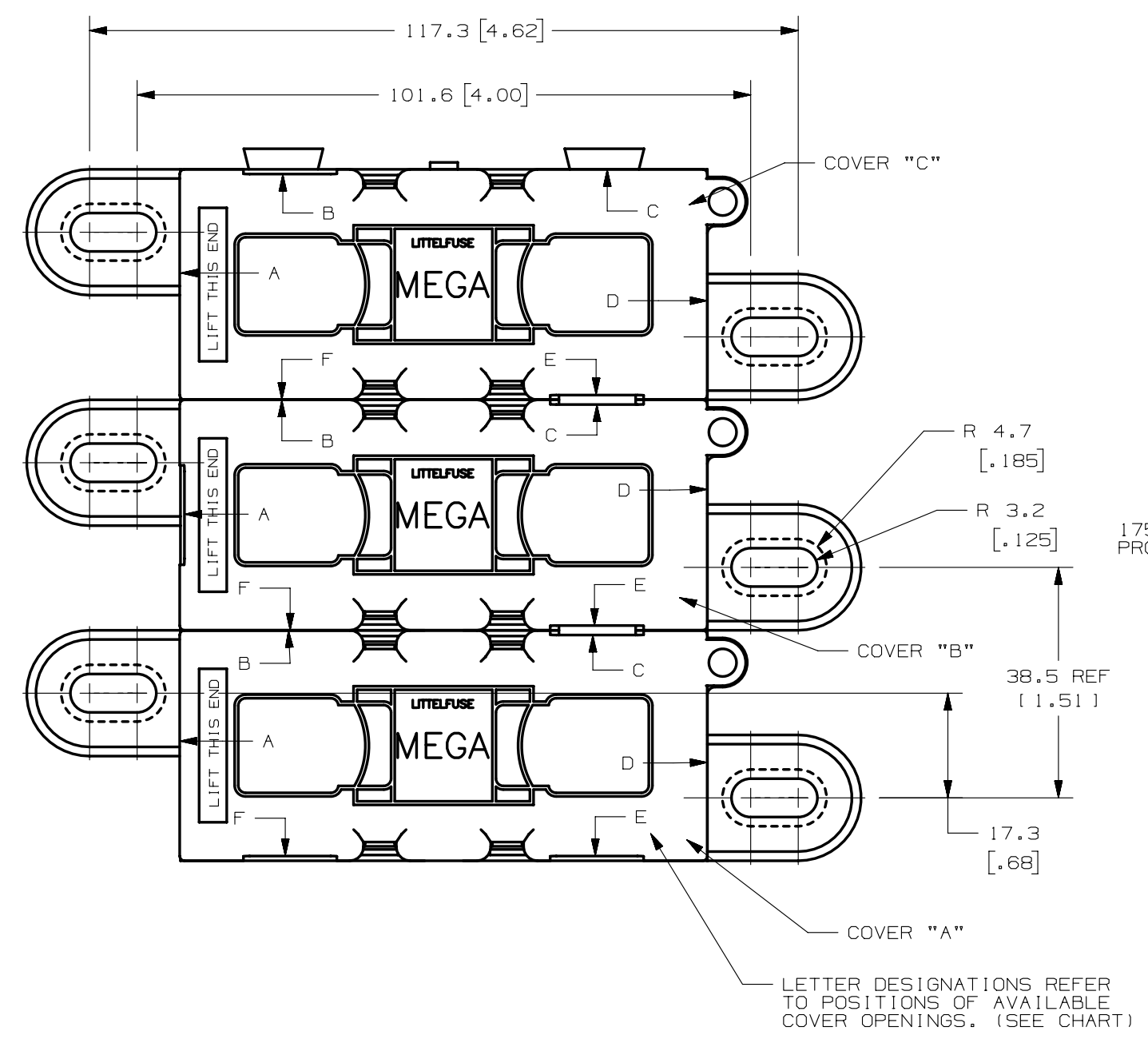

**GENERAL NOTES:**

- COVER RETENTION TEST: MINIMUM FORCE OF 2 LBS. IS REQUIRED TO REMOVE COVER WHEN IT IS SUSPENDED UPSIDE DOWN. FORCE SHALL BE APPLIED THROUGH THE INNER HOLES (2) IN BASE. USE FIXTURE #T-C403 TO SUPPORT PART.
- TORQUE APPLIED TO ALL "TORQUE" LOCATIONS TORQUE REQUIREMENTS FOR THE HEX NUT USED TO SECURE THE BUSSBAR OR THE CUSTOMER RING TERMINAL TO THE MEGA FUSE TO BE:  
8mm NUT - 12-18 NEWTON METERS [ 106-159 IN-LBS ]
- HOLDER MEETS L/F VALIDATION TEST SPEC. VS-005002.
- FLANGED LOCKNUT TO MEET THE FOLLOWING CRITERIA:  
FORD PART NO. W520202  
FINISH: S437.

- MANUALLY ASSEMBLE FLANGED PREVAILING NUT ONTO STUD UP TO THE BOTTOM OF THE PLASTIC INSERT IN THE NUT, FOR ALL "NO TORQUE" LOCATIONS.

- MATERIALS:**
- \* BODY - GLASS FILLED THERMOPLASTIC  
COLOR - BLACK
  - \* COVER - THERMOPLASTIC  
COLOR - BLACK
  - \* WIRE TIE - THERMOPLASTIC  
COLOR - BLACK
  - \* STUDS & NUTS - M8 X 1.25 STEEL ZINC PLATE WITH TRIVALENT CHROMATE, LEACHED AND SEALED, INTEGRAL TORQUE CONTROL LUBRICANT FINISH, (MEETS 96 HR. ASTM STD. B-117 SALT SPRAY REQ.)

NO	COMPONENT NO	DESCRIPTION	QTY/M	U/M
BILL OF MATERIAL				
UNLESS OTHERWISE SPECIFIED, DIMENSIONS ARE IN MILLIMETERS. DIMENSIONS IN BRACKETS [ ] ARE INCHES				
UNLESS OTHERWISE SPECIFIED, DIMENSIONS DO NOT INCLUDE PLATING.				
⊙	DENOTES CRITICAL CHARACTERISTICS.			
CPK	DENOTES CPK DIMENSIONS, -MINIMUM CPK VALUE			
ST	DENOTES A CHARACTERISTIC THAT PROVIDES AN INDICATION OF PROCESS PERFORMANCE. PROCEDURE FOR MEASUREMENT AND TRACKING TO BE DEFINED IN LITTELFUSE INSPECTION INSTRUCTIONS			
CP	DENOTES CP DIMENSIONS, -MINIMUM CP VALUE MUST BE WITHIN THE DIMENSIONAL LIMITATIONS SHOWN ON DRAWING AND INITIALLY LOCATED TO ALLOW FOR MAXIMUM TOOL LIFE			
COPIES TO		MATL SPEC		
1	9	18	FINISH	
2	10	19		
3	12	20		
4	13	21	DRW	GLAB
5	14	23	DATE	05/25/05
6	15	33	SCALE	1:1
7	16	43	CHK	DATE
8	17	53	APPD	DATE
		FINSH GOOD WT		
		GRAMS/PIECE		
TOLERANCE UNLESS OTHERWISE SPECIFIED				
ONE PLACE DEC +/- .3		THREE PLACE DEC +/- .100		
TWO PLACE DEC +/- .25		ANGULAR +/- .1°		
3RD ANGLE PROJECTION				
TITLE		3 POLE MEGA HOLDER FOR 500A & 175A		
Littelfuse		REVISION	DRWG. NO.	OUTLINE
DES PLAINES, ILLINOIS 60016		B	02983002ZXT	

METRIC

CAD GENERATED DRAWING - NO PENCIL CHANGES ALLOWED